

---

## ATTACHMENT A02

### NON-STANDARD WIRING DIAGRAMS FOR MODULAR SOCKETS

(600 TYPE SOCKET TO 8 POSITION MODULAR SOCKET  
CONVERSION FOR CONNECTION MODES 1 – 41)

#### A02.1 What Are Connection Modes?

Connection modes were introduced in conjunction with the Type 611 socket and Type 604 plug circa 1974 for connection of “permitted attachments”, by the then Australian Post Office (later to become Telecom Australia, then Telstra). Connection modes are similar in principle to the original “Registered Jack” (RJ) used in the USA, in that the mode number or RJ number defines the electrical connections (wiring) as well as the type of socket/s used.

“Permitted attachment” was the description used for privately supplied equipment (ie. not supplied or maintained by APO/Telecom). From the mid-1980s the rules for the private supply of customer equipment were relaxed and it was no longer deemed necessary to use Type 611 socket for such equipment unless there was a need for the private equipment and associated socket to switch the line (eg. automatic dialling equipment). Type 605 plug was introduced to connect equipment to either 610 or 611 sockets. Plug Type 603, which was keyed to plug into a 610 socket, and plug Type 604, which would only plug into a 611 socket, became obsolete.

##### A02.1.1 Application of Connection Modes

The 611 socket has three pairs of contact springs which can be adjusted to either close (make) or remain open when the plug is removed. This enables selective automatic through-switching of lines or leads to succeeding sockets or termination on a test network (eg. a diode) if the equipment is unplugged for testing or repair. Figures A02.1 and A02.2 illustrate the principle of switching contact springs.

Since 1989, the perception by some has been that connection modes have no place in a deregulated industry. However, connection modes are still specified for connection of some equipment, eg. security/medical alarms, modems, NTUs, point-to-point lines (“private” lines), etc. Also, connection modes may still be a useful tool in defining standardised connection arrangements (as were the original RJ numbers in the USA), so the principle has been continued in Attachment A01 for 8 position modular sockets for reference by Telstra. There is no obligation to comply.

##### A02.1.2 Use of this Attachment

Until now details of existing connection modes and applicable wiring arrangements could only be found in old Telecom Australia handbooks which have long been out of print. This Attachment addresses that deficiency. This Attachment also provides information for adaptation of 8 position modular sockets to existing connection modes for repair of existing installations and installation of equipment that still uses a 600 type plug.

**Figure A02.1 — Line switching equipment plugged into any socket**

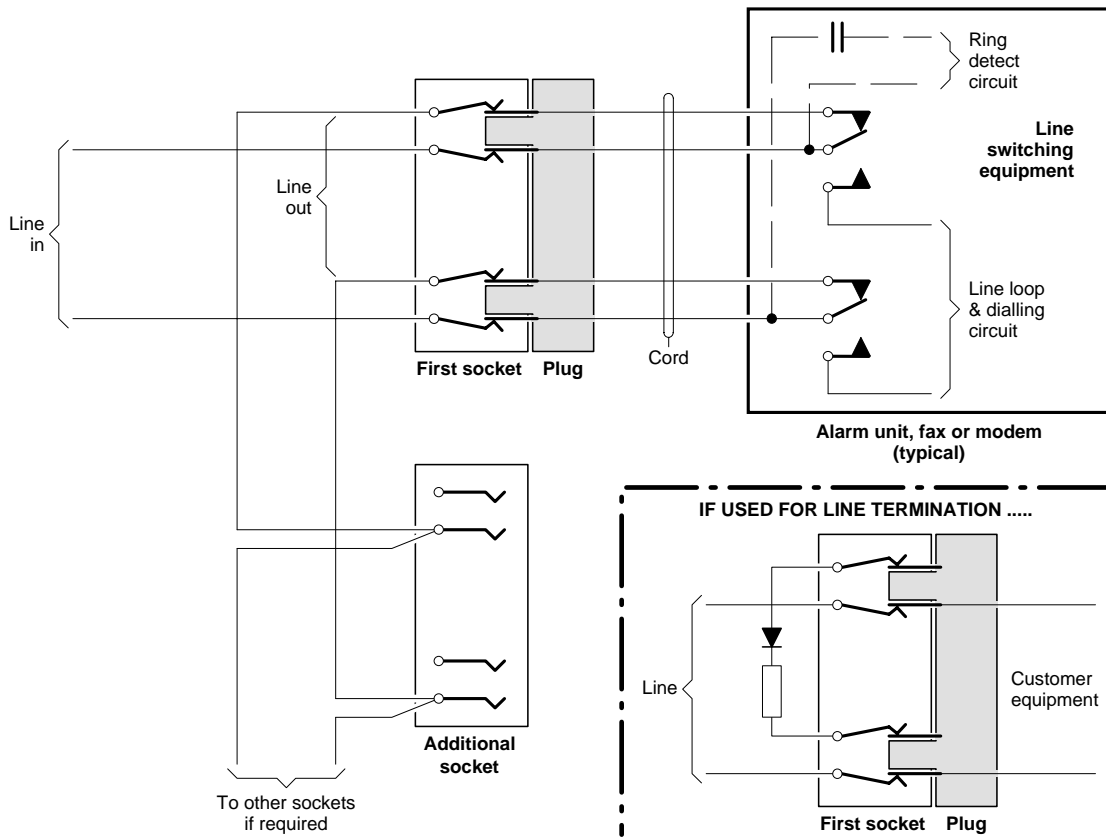

**Figure A02.2 — Operation of “switching” socket when equipment unplugged**

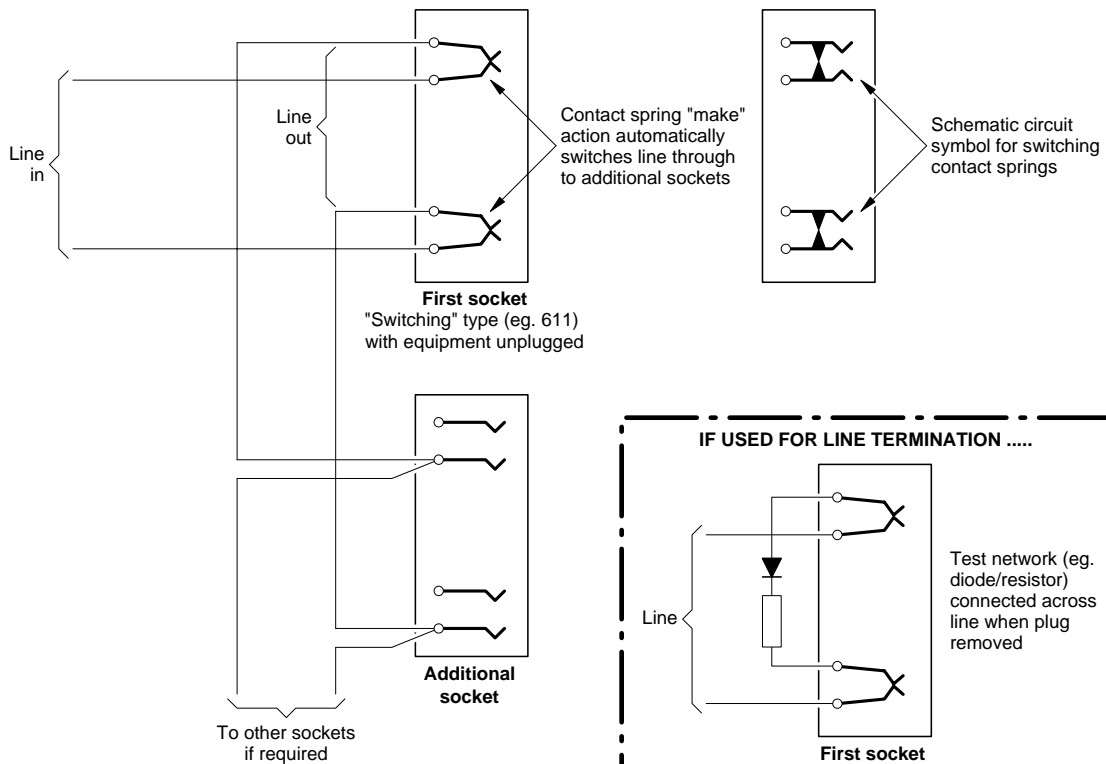

## A02.2 Connection Mode Description and Equivalence Table

Reproduced in Table A02.1 is a brief description and wiring diagram for each connection mode that existed prior to 1989 (modes 1-41) using socket type 611.

Included are equivalent connection modes using 8 position modular sockets. Equivalent modular socket connection modes are described at the end of this Attachment and are prefixed “M” for “Modular”.

For new equipment design, use a “standard” connection mode as described in Attachment A01. The “standard” connection modes per Attachment A01 are numbered 81-89 with subsets of each mode being designated alphabetically, eg. 81A, 81B, etc. Refer Attachment A01 for more details.

**Table A02.1 — Connection Mode Equivalence Table**

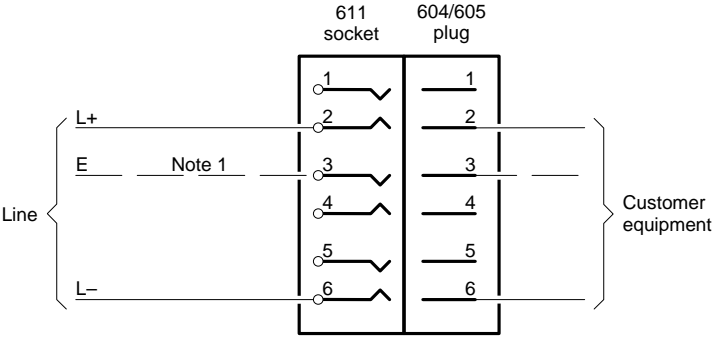
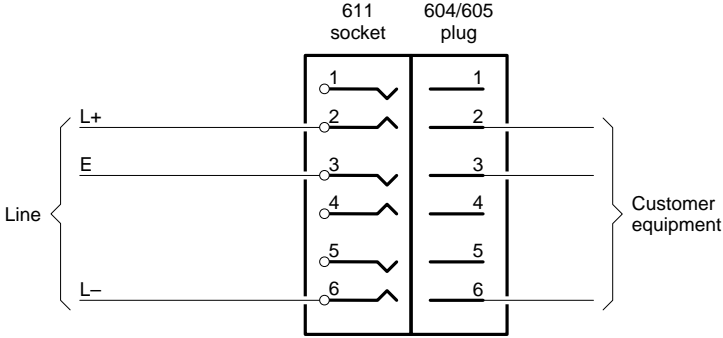
Old Mode	Brief description	Original wiring using 611 socket	New Mode
1	Exchange line or PBX extension — no switching of line on removal of plug  Reference: CE-99038 sheet 2	 <p>611 socket      604/605 plug</p> <p>Line { L+ ——— 2, E ——— 3, L- ——— 6 } } Customer equipment</p> <p>NOTES: 1. If earth is required for recall, connect as shown thus — — — — —                  2. This wiring arrangement differs from normal 610 socket wiring in that the optional recall earth is connected to terminal 3 instead of terminal 1.</p>	M 1 (no earth)  or  M 2 or M 40 (if earth reqd.)
2	Exchange line or PBX extension, requiring earth — no switching of line on removal of plug  Reference: CE-99038 sheet 3	 <p>611 socket      604/605 plug</p> <p>Line { L+ ——— 2, E ——— 3, L- ——— 6 } } Customer equipment</p> <p>NOTES: 1. This wiring arrangement differs from normal 610 socket wiring in that the recall earth is connected to terminal 3 instead of terminal 1.</p>	M 2 or M 40

<p>3</p> <p>Exchange line or PBX extension — both legs switched on removal of plug</p> <ul style="list-style-type: none"> <li>commonly used for connection of security/medical alarm diallers, modems, faxes and telephone answering machines</li> </ul> <p>Reference: CE-99038 sheet 4</p>	<p>611 socket      604/605 plug</p> <p>Line in { L+ E L- }</p> <p>Note 1</p> <p>Note 2</p> <p>Customer equipment</p> <p>Line out to other socket/s</p> <p>NOTES: 1. If earth is required for recall, connect as shown thus - - - - - 2. Connection of these terminals required only where the customer equipment incorporates facilities for line switching.</p>	<p>M 3 (no earth) or M 4 (if earth reqd.)</p>
<p>4</p> <p>Exchange line or PBX extension, requiring earth — both legs switched on removal of plug</p> <p>Reference: CE-99038 sheet 5</p>	<p>611 socket      604/605 plug</p> <p>Line in { L+ E L- }</p> <p>Note 1</p> <p>Note 2</p> <p>Customer equipment</p> <p>Line out to other socket/s</p> <p>NOTES: 1. If earth is required at other socket/s, connect as shown thus - - - - - 2. Connection of these terminals required only where the customer equipment incorporates facilities for line switching.</p>	<p>M 4</p>
<p>5</p> <p>Exchange line or PBX extension — one leg switched on removal of plug</p> <ul style="list-style-type: none"> <li>commonly used for connection of repertory diallers</li> </ul> <p>Reference: CE-99038 sheet 6</p>	<p>611 socket      604/605 plug</p> <p>Line in { L+ E L- }</p> <p>Note 1</p> <p>Note 2</p> <p>Customer equipment</p> <p>Line out to other socket/s</p> <p>NOTES: 1. If earth is required for recall, connect as shown thus - - - - -</p>	<p>M 5 (no earth) or M 6 (if earth reqd.)</p>

<p>6</p> <p>Exchange line or PBX extension, requiring earth — one leg switched on removal of plug</p> <p>Reference: CE-99038 sheet 7</p>		<p>611 socket</p> <p>604/605 plug</p> <p>Line in</p> <p>Note 1</p> <p>Line out to other socket/s</p> <p>Customer equipment</p> <p>NOTES: 1. If earth is required at other socket/s, connect as shown thus — — —</p>	<p>M 6</p>
<p>7</p> <p>Exchange line or PBX extension — manual switching of both legs by changeover (C/O) switch</p> <p>Reference: CE-99038 sheet 8</p>		<p>611 socket</p> <p>604/605 plug</p> <p>Line in</p> <p>Note 1</p> <p>C/O switch</p> <p>Line out to other socket/s</p> <p>Customer equipment</p> <p>NOTES: 1. If earth is required at other socket/s, connect as shown thus — — —</p>	<p>M 7</p>

<p>8</p> <p>Exchange line or PBX extension, requiring earth — manual switching of both legs by changeover (C/O) switch</p> <p>Reference: CE-99038 sheet 9</p>	<p>611 socket 604/605 plug</p> <p>Line in</p> <p>C/O switch</p> <p>Note 1</p> <p>Note 2</p> <p>Customer equipment</p> <p>Line out to other socket/s</p> <p>NOTES: 1. If earth is required at other socket/s, connect as shown thus — — — 2. This wiring arrangement differs from normal 610 socket wiring in that the earth is connected to terminal 3 instead of terminal 1.</p>	<p>M 8</p>
<p>9</p> <p>Exchange line or PBX extension to Recorder Connector Type 1 Mark 2</p> <p>Reference: CE-99038 sheet 10</p>	<p>611 socket 604/605 plug</p> <p>Line in</p> <p>Recorder Connector Type 1 Mark 2</p> <p>Private 12 V d.c. power supply</p> <p>Cannon plug type XLR-APO-11 CUR</p> <p>Recorder</p> <p>Line out to other socket/s</p> <p>NOTES: 1. If earth is required for recall, connect as shown thus - - - - -</p>	<p>M 9</p>

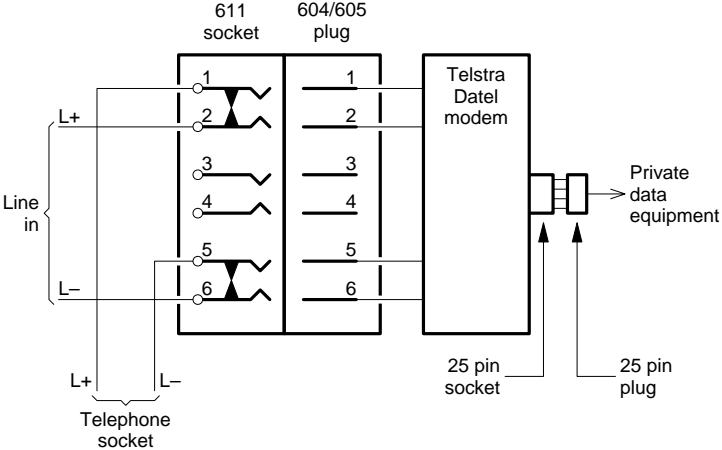
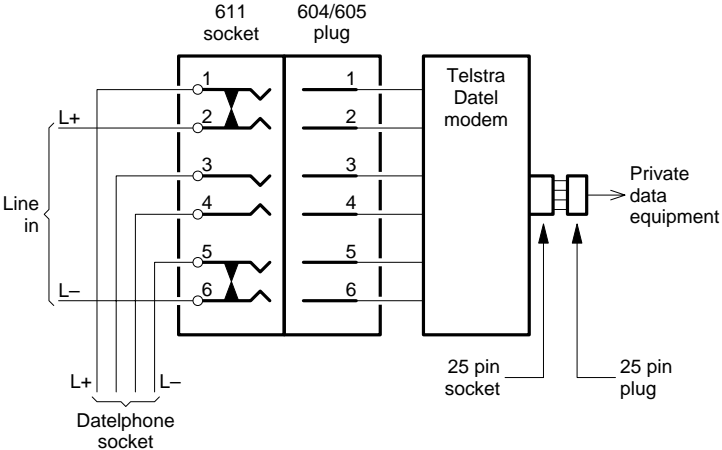
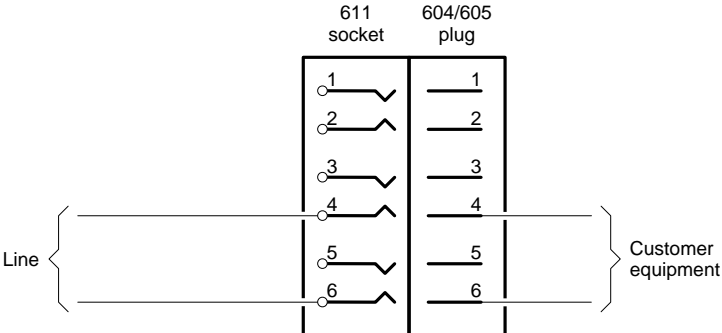
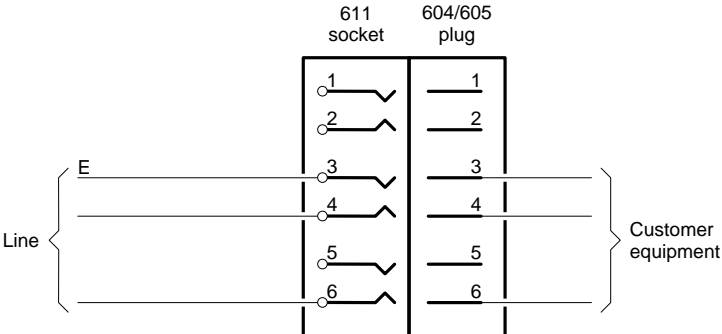
<p>10</p> <p>Exchange line to Datel modem with manual switching</p> <p>Reference: CE-99038 sheet 11</p>			<p>M 3</p>
<p>11</p> <p>Exchange line to Datel modem with automatic switching</p> <p>Reference: CE-99038 sheet 11</p>			<p>M 11</p>
<p>12</p> <p>Private line (2 wire)</p> <ul style="list-style-type: none"> <li>typically used for connection of music on hold or external control functions to Commander® or PABX systems</li> </ul> <p>Reference: CE-99038 sheet 12</p>			<p>M 12</p>
<p>13</p> <p>Private line (2 wire), requiring earth</p> <p>Reference: CE-99038 sheet 13</p>			<p>M 13</p>

<p>14</p>	<p>Private line (2 wire) — terminated with diode when plug removed</p> <ul style="list-style-type: none"> <li>typically used for background music distribution</li> </ul> <p>Reference: CE-99038 sheet 14</p>	<p>611 socket      604/605 plug</p> <p>Line { } Customer equipment</p> <p>NOTES: 1. Some areas (eg. Qld) used a diode/resistor combination thus: </p>	<p>M 14</p>
<p>15</p>	<p>Private line (2 wire), requiring earth — terminated with diode when plug removed</p> <p>Reference: CE-99038 sheet 15</p>	<p>611 socket      604/605 plug</p> <p>Line { } Customer equipment</p> <p>NOTES: 1. Some areas (eg. Qld) used a diode/resistor combination thus: </p>	<p>M 15</p>
<p>16</p>	<p>Private line (4 wire)</p> <ul style="list-style-type: none"> <li>Commonly used for connection of a line isolation unit (LIU) to a Commander® or PABX system</li> <li>Where connection at other end of private line has lines 1 and 2 reversed (transposed send/receive pairs), it is sometimes called "mode 61".</li> </ul> <p>Reference: CE-99038 sheet 16</p>	<p>611 socket      604/605 plug</p> <p>Line 1 { } Customer equipment</p> <p>Line 2 { }</p>	<p>M 16</p>
<p>17</p>	<p>Private line (4 wire) — terminated with diodes when plug removed</p> <ul style="list-style-type: none"> <li>This is the standard DDN NTU termination.</li> <li>Where the connection at the other end of the private line has Line 1 and Line 2 reversed (eg. transposed send/receive pairs), it is sometimes referred to as "mode 71".</li> </ul> <p>Reference: CE-99038 sheet 17</p>	<p>611 socket      604/605 plug</p> <p>Line 1 { } Customer equipment</p> <p>Line 2 { }</p> <p>NOTES: 1. Some areas (eg. Qld) used a diode/resistor combination thus: </p>	<p>M 17</p>

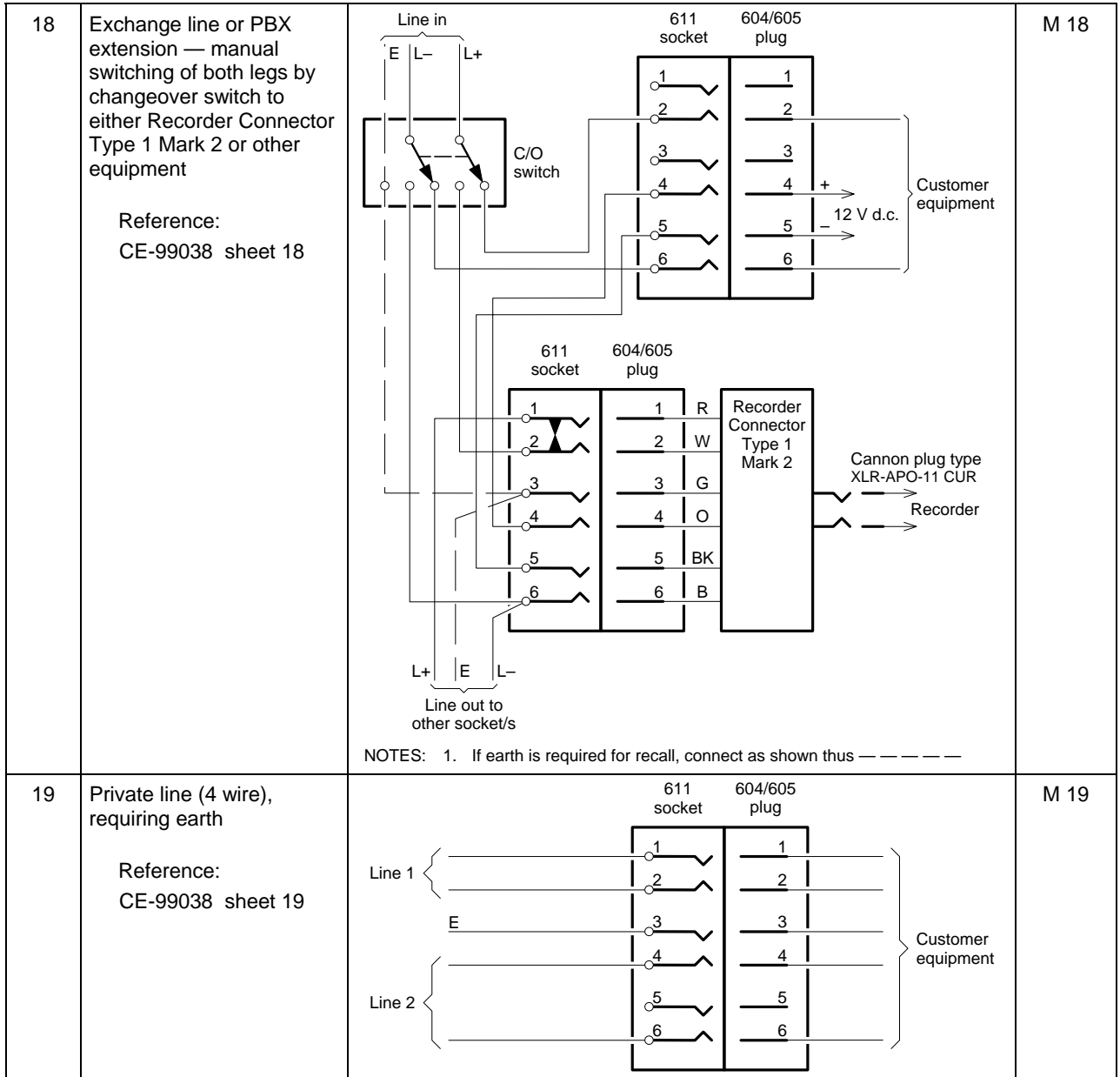

<p>20</p>	<p>Private line (dual 2 wire) — loopback facility using dual plug/socket</p> <p>Reference: CE-99038 sheet 20</p>	<p>611 socket      604/605 plug</p> <p>Line 1</p> <p>Customer equipment</p> <p>611 socket      604/605 plug</p> <p>Line 2</p> <p>Customer equipment</p>	<p>M 20</p>
<p>21</p>	<p>Type 2 PMBX extension (4 wire) — one leg and earth switched on removal of plug</p> <p>Reference: CE-99038 sheet 21</p>	<p>611 socket      604/605 plug</p> <p>PMBX extension</p> <p>Line out to other socket/s</p> <p>Customer equipment</p> <p>Supvn. C leads</p>	<p>— (Type 2 PMBX extinct)</p>

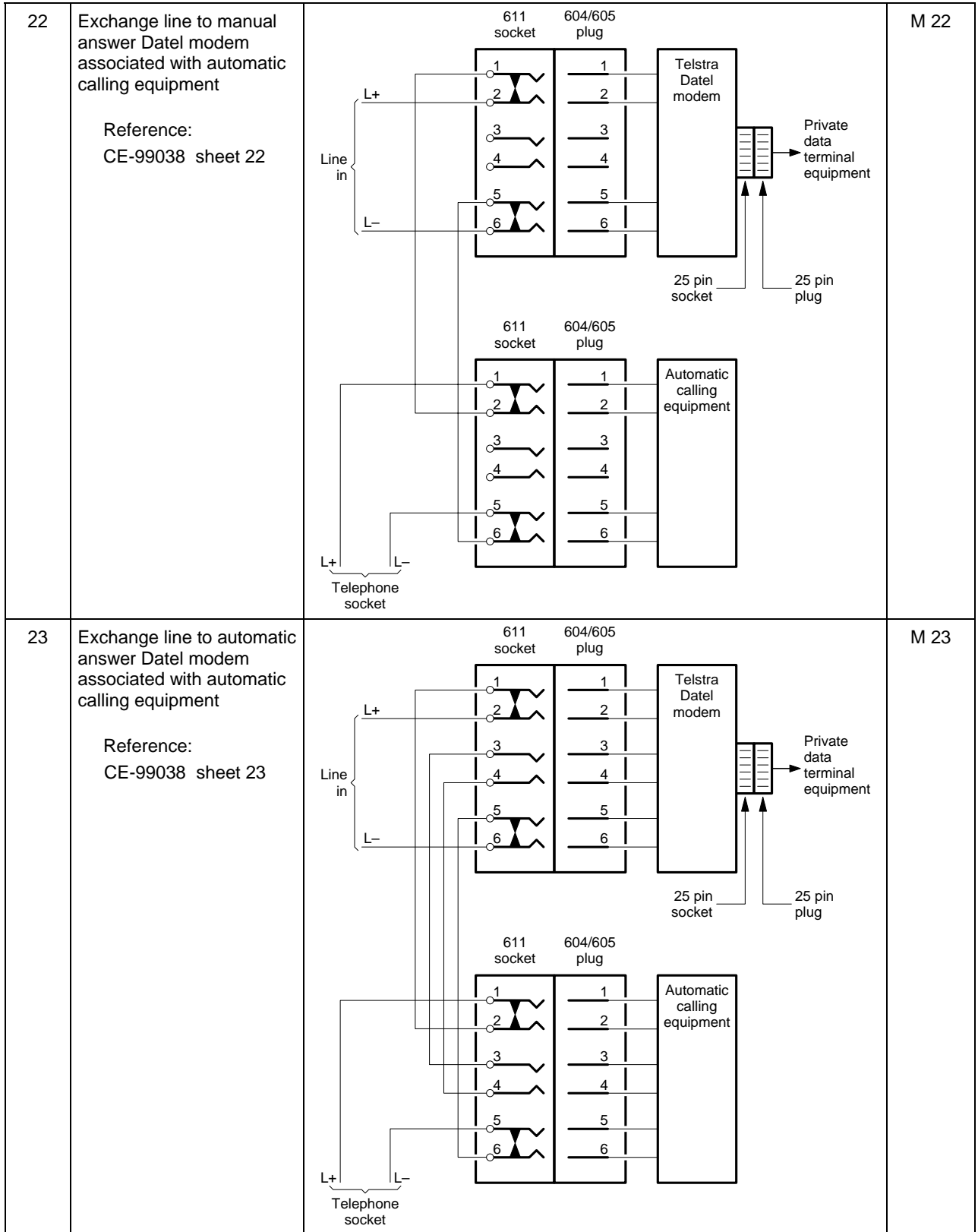

<p>24</p> <p>Exchange line to automatic answer Datel modem (with manual answer facilities) associated with automatic calling equipment</p> <p>Reference: CE-99038 sheet 24</p>	<p>Reference: CE-99038 sheet 24</p>	<p>611 socket 604/605 plug</p> <p>Line in</p> <p>L+ L-</p> <p>1 2 3 4 5 6</p> <p>Telstra Datel modem</p> <p>25 pin socket 25 pin plug</p> <p>Private data terminal equipment</p> <p>611 socket 604/605 plug</p> <p>1 2 3 4 5 6</p> <p>Automatic calling equipment</p> <p>L+ L- E C</p> <p>Telephone socket (Note 1)</p> <p>NOTES: 1. The telephone used shall be wired in accordance with that required for connection to a Type 2 PMBX extension line (C &amp; E leads connected to hook switch break contact, ie. contact opens when handset lifted).</p>	<p>M 24</p>
<p>25</p> <p>Exchange line or PBX extension with series ring detect facility — one leg switched on removal of plug</p> <p>Reference: CE-99038 sheet 25</p>	<p>Reference: CE-99038 sheet 25</p>	<p>611 socket 604/605 plug</p> <p>Line</p> <p>L+ L- E Note 1</p> <p>1 2 3 4 5 6</p> <p>Customer equipment</p> <p>610 socket</p> <p>1 2 3 Note 2 4 5 6</p> <p>NOTES: 1. If earth is required for recall, connect as shown thus — — — — — 2. In 610 socket remove link between terminals 2 and 3.</p>	<p>M 25</p>

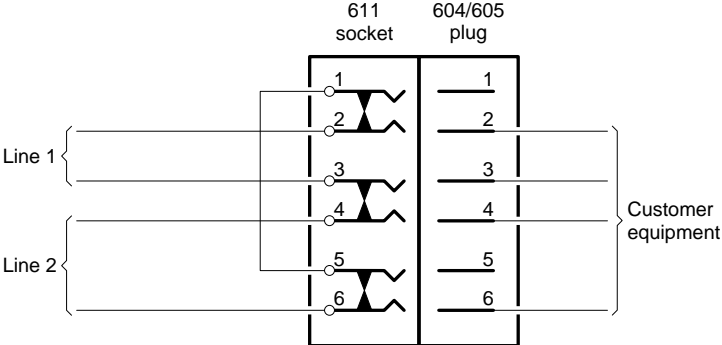
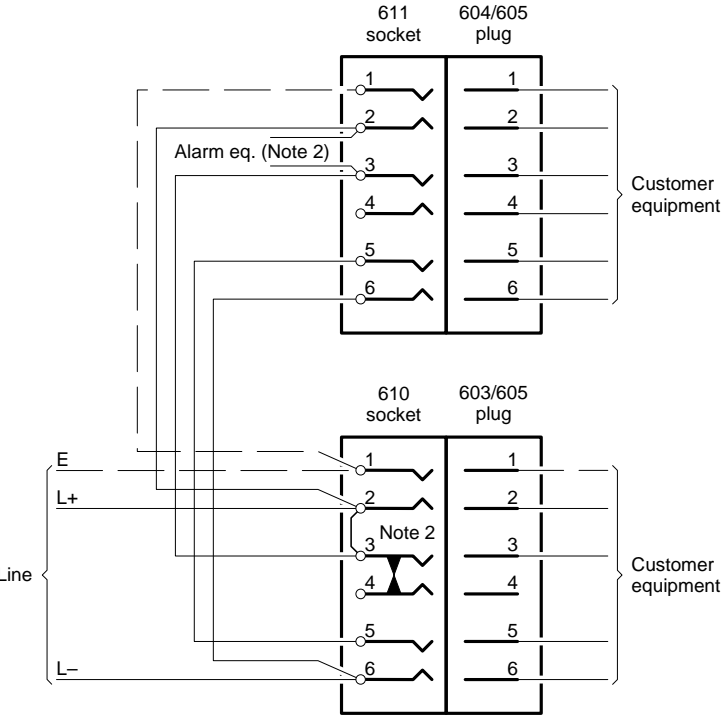
<p>26</p>	<p>Private line (4 wire) — terminated to allow through connection between lines 1 and 2 when plug removed</p> <p>Reference: CE-99038 sheet 26</p>		<p>M 26</p>
<p>27</p>	<p>Exchange line or PBX extension — connection of private telephone on composite service</p> <p>Reference: CE-99038 sheet 27</p>	 <p>NOTES: 1. If earth is required for recall, connect as shown thus — — — — — 2. If alarm equipment is required, connect between terminals 2 and 3 of either socket and remove link between terminals 2 and 3 in 610 socket.</p>	<p>M 27</p>

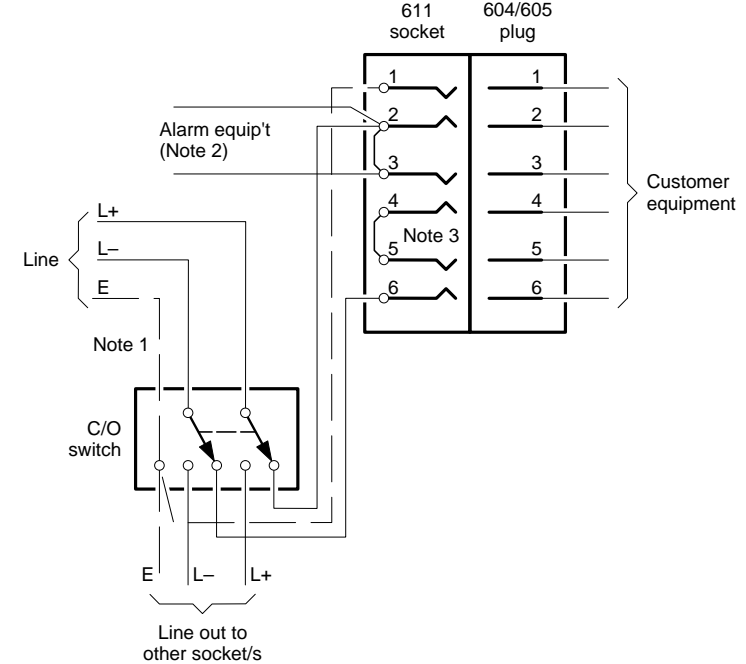
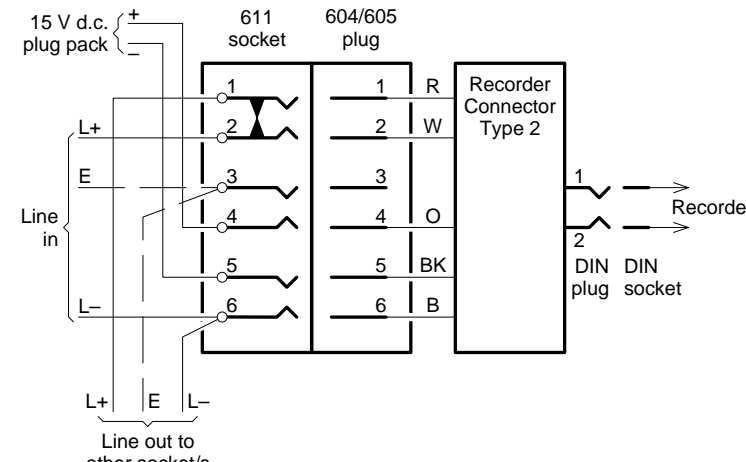
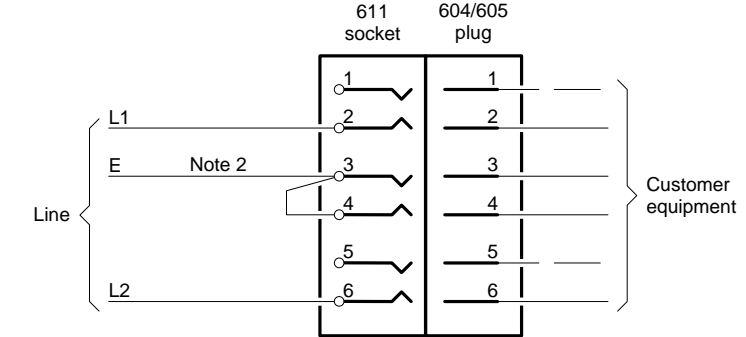
<p>28</p> <p>Exchange line or PBX extension — telephone type equipment with 6 conductor line cord, connected as alternative equipment (via changeover switch) or sole termination</p> <p>Reference: CE-99038 sheet 28</p>	 <p>611 socket      604/605 plug</p> <p>Alarm equip't (Note 2)</p> <p>Line</p> <p>L+ L- E</p> <p>Note 1</p> <p>C/O switch</p> <p>E L- L+</p> <p>Line out to other socket/s</p> <p>Customer equipment</p> <p>NOTES: 1. If earth is required for recall, connect as shown thus — — — — — 2. Strap terminals 2 and 3 in 611 socket, except where alarm equipment is required, in which case connect alarm between 2 and 3. 3. Strap terminals 4 and 5 in 611 socket.</p>	<p>M 28</p>
<p>29</p> <p>Exchange line or PBX extension to Recorder Connector Type 2</p> <p>Reference: CE-99038 sheet 29</p>	 <p>15 V d.c. plug pack</p> <p>611 socket      604/605 plug</p> <p>Line in</p> <p>L+ E L-</p> <p>L+ E L-</p> <p>Line out to other socket/s</p> <p>Recorder Connector Type 2</p> <p>Recorder DIN plug socket</p> <p>NOTES: 1. If earth is required for recall, connect as shown thus — — — — —</p>	<p>M 9</p>
<p>30</p> <p>Private line (2 wire) and earth — telegraph type applications</p> <p>Reference: CE-99038 sheet 30</p>	 <p>611 socket      604/605 plug</p> <p>Line</p> <p>L1 E L2</p> <p>Note 2</p> <p>Customer equipment</p> <p>NOTES: 1. For telegraph, data and similar applications where identification of line conductors is required, the terminations of the line will be as follows:- Terminal 2 is the 'Receive' of the terminal equipment (L1) Terminal 6 is the 'Send' of the terminal equipment (L2). 2. This mode may be specified without an earth connection, but in all applications terminals 3 and 4 will be strapped.</p>	<p>M 30</p>

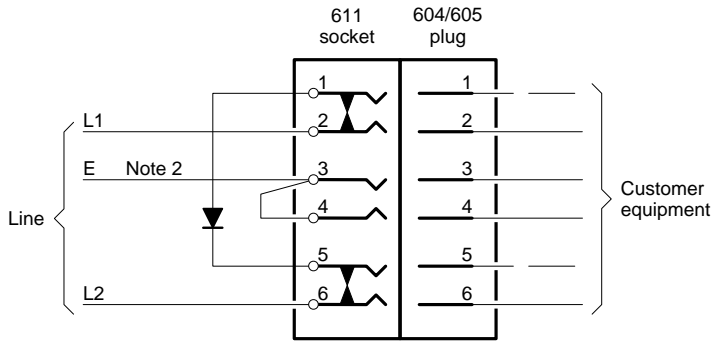
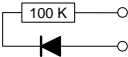
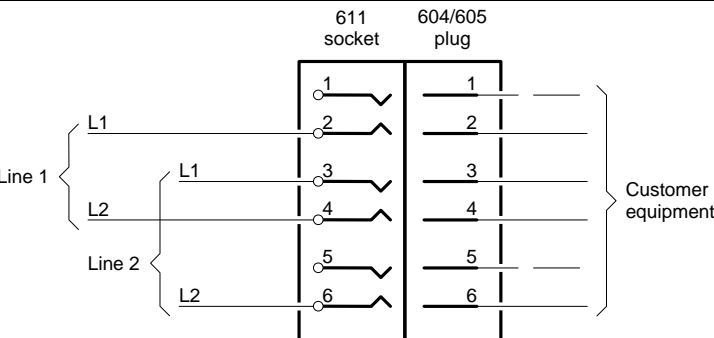
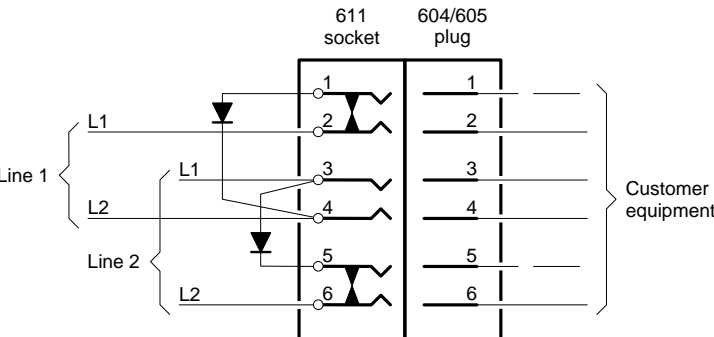
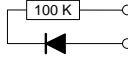
<p>31</p> <p>Private line (2 wire) and earth — telegraph type applications, line terminated with diode when plug not inserted</p> <p>Reference: CE-99038 sheet 31</p>	 <p>611 socket</p> <p>604/605 plug</p> <p>Line</p> <p>E Note 2</p> <p>L1</p> <p>L2</p> <p>Customer equipment</p> <p>NOTES:</p> <ol style="list-style-type: none"> <li>1. For telegraph, data and similar applications where identification of line conductors is required, the terminations of the line will be as follows:- Terminal 2 is the 'Receive' of the terminal equipment (L1) Terminal 6 is the 'Send' of the terminal equipment (L2).</li> <li>2. This mode may be specified without an earth connection, but in all applications terminals 3 and 4 will be strapped.</li> <li>3. Some areas (eg. Qld) used a diode/resistor combination thus:</li> </ol> 	<p>M 31</p>
<p>32</p> <p>Private line (2 wire or 4 wire) — telegraph type applications</p> <p>Reference: CE-99038 sheet 32</p>	 <p>611 socket</p> <p>604/605 plug</p> <p>Line 1</p> <p>Line 2</p> <p>Customer equipment</p> <p>NOTES:</p> <ol style="list-style-type: none"> <li>1. Either Line 1 or Line 2, or both Line 1 and Line 2, may be connected.</li> <li>2. For telegraph, data and similar applications where line identification is required, the terminations of the lines will be as follows:- Terminals 2 and 4 are the 'Receive' of the terminal equipment (Line 1) Terminals 3 and 6 are the 'Send' of the terminal equipment (Line 2).</li> </ol>	<p>M 32</p>
<p>33</p> <p>Private line (2 wire or 4 wire) — telegraph type applications, lines terminated with diode when plug not inserted</p> <p>Reference: CE-99038 sheet 33</p>	 <p>611 socket</p> <p>604/605 plug</p> <p>Line 1</p> <p>Line 2</p> <p>Customer equipment</p> <p>NOTES:</p> <ol style="list-style-type: none"> <li>1. Either Line 1 or Line 2, or both Line 1 and Line 2, may be connected.</li> <li>2. For telegraph, data and similar applications where line identification is required, the terminations of the lines will be as follows:- Terminals 2 and 4 are the 'Receive' of the terminal equipment (Line 1) Terminals 3 and 6 are the 'Send' of the terminal equipment (Line 2).</li> <li>3. Some areas (eg. Qld) used a diode/resistor combination thus:</li> </ol> 	<p>M 33</p>

<p>34</p>	<p>Exchange line or PBX extension — connection of equipment with series ring detect facility only</p> <p>Reference: CE-99038 sheet 34</p>	<p>611 socket</p> <p>604/605 plug</p> <p>Line { L+ E Note 1 L- }</p> <p>Customer equipment</p> <p>610 socket</p> <p>Note 2</p> <p>NOTES: 1. If earth is required for recall, connect as shown thus - - - - - 2. In 610 socket remove link between terminals 2 and 3.</p>	<p>M 34</p>
<p>35</p>	<p>PBX extension requiring negative battery and earth</p> <p>Reference: CE-99038 sheet 35</p>	<p>611 socket</p> <p>604/605 plug</p> <p>Line { L+ Battery feed { E (+) - L- }</p> <p>Customer equipment</p>	<p>M 35</p>

<p>36</p> <p>Telex line or private line (2 wire) and earth — private equipment with standby or alternative teleprinter(s)</p> <p>Reference: CE-99038 sheet 36</p>	<p>611 socket</p> <p>604/605 plug</p> <p>Line</p> <p>L1</p> <p>E</p> <p>L2</p> <p>Private equipment</p> <p>Telstra teleprinter Note 1</p> <p>611 socket Note 2</p> <p>NOTES: 1. For telegraph, data and similar applications where identification of line conductors is required, the terminations of the line will be as follows:- Terminal 2 is the 'Receive' of the terminal equipment (L1) Terminal 6 is the 'Send' of the terminal equipment (L2). 2. To 611 socket for second teleprinter, where two machines are required for duplex operation.</p>	<p>M 36</p>
<p>37</p> <p>Exchange line or PBX extension to private radio service — radio service provides sole line termination</p> <p>Reference: CE-99038 sheet 37</p>	<p>611 socket</p> <p>604/605 plug</p> <p>Line</p> <p>L+</p> <p>E</p> <p>L-</p> <p>Note 1</p> <p>Radio interface</p> <p>NOTES: 1. If earth is required for recall, connect as shown thus — — — — —</p>	<p>M 37</p>

<p>38</p>	<p>Exchange line or PBX extension to private radio service — both legs switched to either radio interface or telephone by changeover switch</p> <p>Reference: CE-99038 sheet 38</p>	<p>611 socket      604/605 plug</p> <p>Line in: L+, L-, E</p> <p>Radio interface terminals: 1, 2, 3, 4, 5, 6</p> <p>C/O switch</p> <p>Line out to telephone socket/s: E, L-, L+</p> <p>NOTES: 1. If earth is required for recall, connect as shown thus — — — — —</p>	<p>M 38</p>
<p>39</p>	<p>Exchange line or PBX extension to private radio service — both legs switched to telephone on removal of plug or by changeover facility in the radio interface while plug is inserted</p> <p>Reference: CE-99038 sheet 39</p>	<p>611 socket      604/605 plug</p> <p>Line in: L+, L-, E</p> <p>Radio interface terminals: 1, 2, 3, 4, 5, 6</p> <p>Line out to other socket/s: L+, E, L-</p> <p>NOTES: 1. If earth is required for recall, connect as shown thus — — — — — 2. Connection of these terminals required only where radio interface incorporates facilities for line switching.</p>	<p>M 39</p>

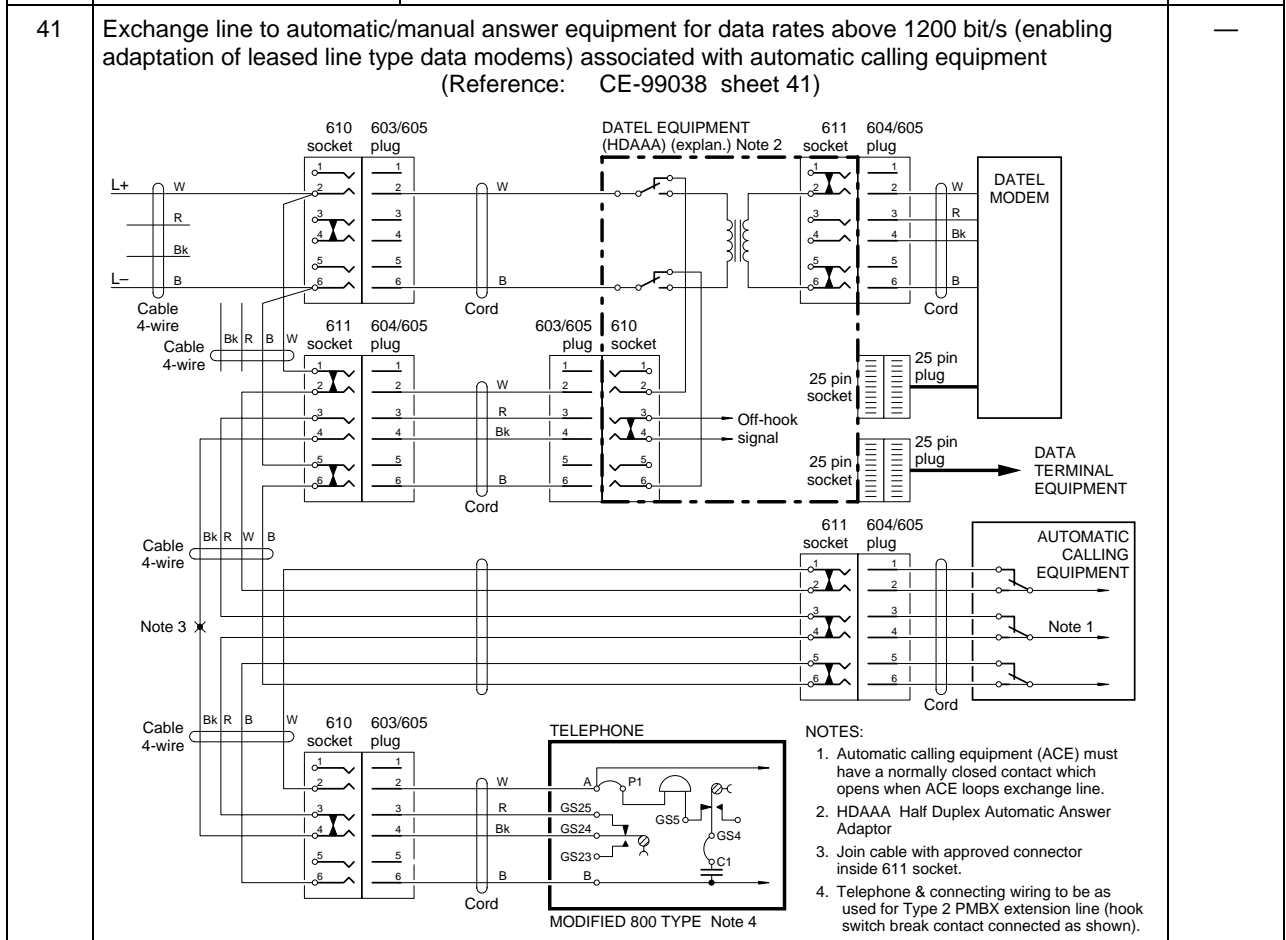
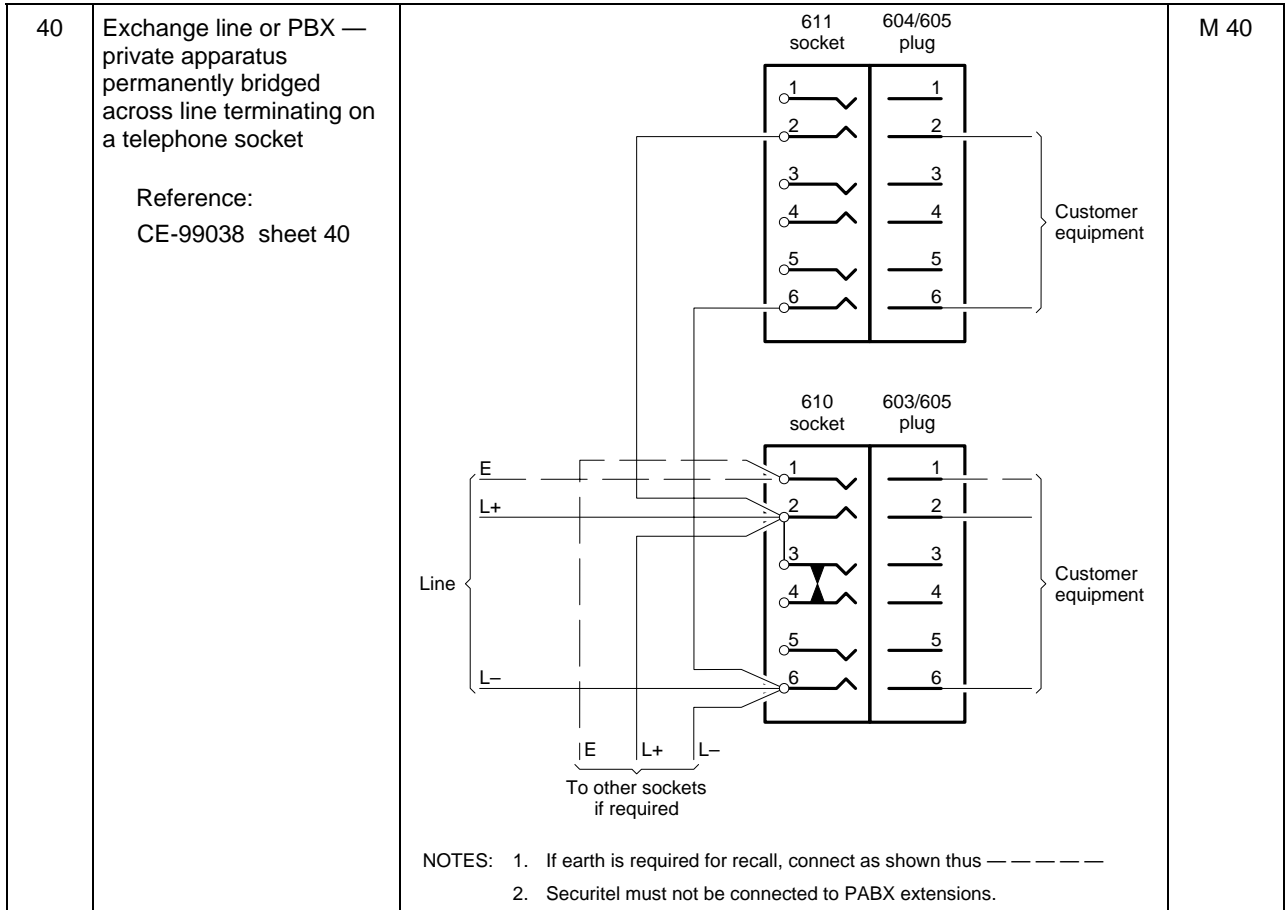

## A02.3 Connection Modes Using Modular Sockets

Telstra's new modular socket range includes a switching socket for use in the most common connection modes where a 611 socket would otherwise be used. However, switching modular sockets only have two pairs of contact springs that make when the plug is removed, and the make action cannot be disabled. Thus, not all "switching" connection modes can be directly translated to modular sockets, but many of the more complex modes are no longer used for new installations anyway.

Reproduced on the following pages are connection modes with 611 socket contacts translated to 8 position modular socket contacts in accordance with Table A02.2. The modular connection modes have the same mode number as the equivalent 611 socket connection mode, but are prefixed "M" for "Modular".

The following abbreviations are used to describe the type of modular socket to be used for connection modes:

600 Socket	8 Position Socket	Pair No.
2	5	Pair 1
6	4	1
1	6	Pair 2
5	3	2
3	1	Pair 3
4	2	3
	7	Pair 4
	8	4

**8P4C** **8** Position, **4** Contact — standard socket S.268/00143 with grey front.

**8P4S** **8** Position, **4** Switching contacts — socket S.268/00144 with blue front.

This socket must **not** be used where an 8P4C or 8P8C socket is specified.

**8P8C** **8** Position, **8** Contact — socket S.268/00153 with white front. This socket may also be used where an 8P4C socket is specified.

The connection mode wiring diagrams for the modular sockets are intended to allow reconnection of existing customer equipment using the existing equipment line cord and (600 type) plug with adaptor cord S.268/00151. Where a simple translation of socket connections per Table A02.2 may result in split cable pairs in pre-cabled buildings (see A02.4), alterations are required in the adaptor cord to maintain cable balance and minimise crosstalk. In all cases, the equivalent "standard" connection mode (per Attachment A01) is identified for any new equipment design. All modular connection modes are shown with the adaptor cord S.268/00151 being used to connect the customer equipment via the original 600 type plug.

*If you need to replace an existing 600 type socket with a modular socket (eg. for maintenance) and you are unable to work out what connection mode was originally used to connect the equipment:*

- on a piece of paper, record the existing cable conductor colours and 600 type socket connections (contact numbers);
- using Table A02.2, on your notes cross out each 600 type socket contact number and replace it with the equivalent modular socket contact number;
- replace the 600 type socket with an 8P8C modular socket (S.268/00153);
- using your notes as a guide, reconnect the conductors on the modular socket;
- connect the equipment via an adaptor cord S.268/00151 (using the original 600 type equipment plug).
- Socket contact switching and/or diode test termination must be foregone.

## A02.4 Connecting Equipment via Integrated Building Cabling

Where it is intended to connect equipment, for which a connection mode is specified, via horizontal cabling installed in accordance with AS/NZS 3080 or AS/NZS 3086:

- do *not* alter the 4-pair cable terminations at the distributor or the TO;
- do *not* replace the TO with a switching type socket (if specified for the particular connection mode) without the express permission of the owner of the cabling;
- adapt the existing telecommunications outlet (TO) and wiring to the mode required (by appropriate cross-connections at the distributor); and
- if the equipment must be connected via an adaptor cord, if necessary modify the adaptor cord connections within the 600 socket as described for the particular connection mode on the following pages.

The two common wiring schemes for TOs installed in accordance with AS/NZS 3080 and AS/NZS 3086 are illustrated in Figure A02.3.

**Figure A02.3 — Colour code and pair assignments for integrated cabling**

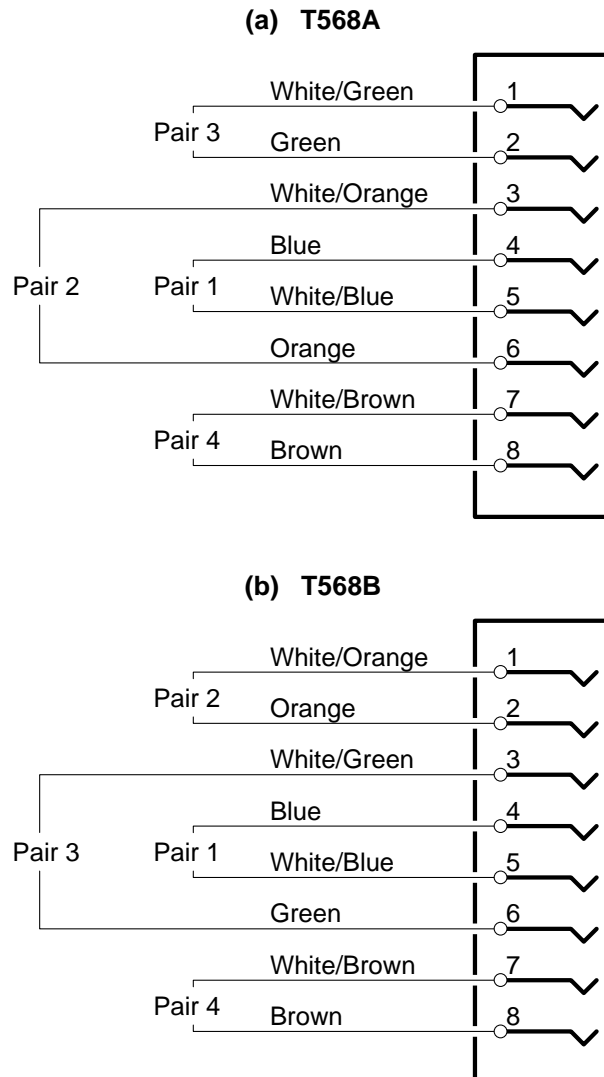

Note: T568A is the preferred wiring arrangement and should apply to most new installations. Whether T568A or T568B standard applies can be verified by checking the distributor and/or TO wiring.

### Mode M 1 2-wire line with no earth

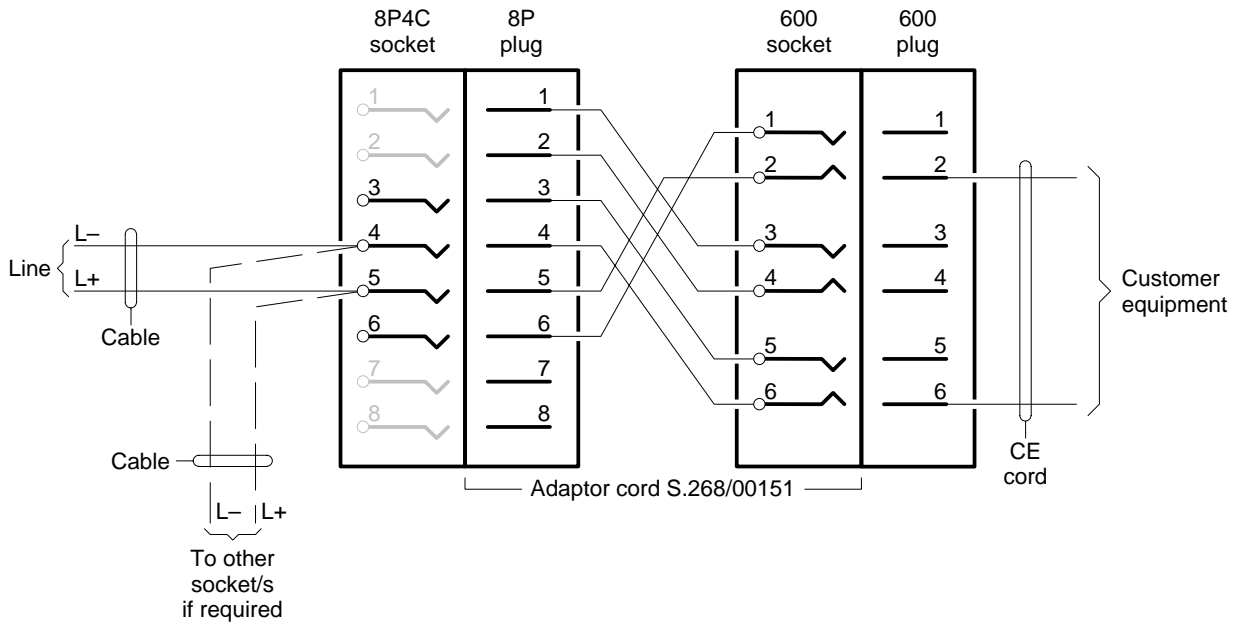

Note: The equivalent standard connection mode per Attachment A01 is mode 81A.

### Mode M 2 2-wire line with earth

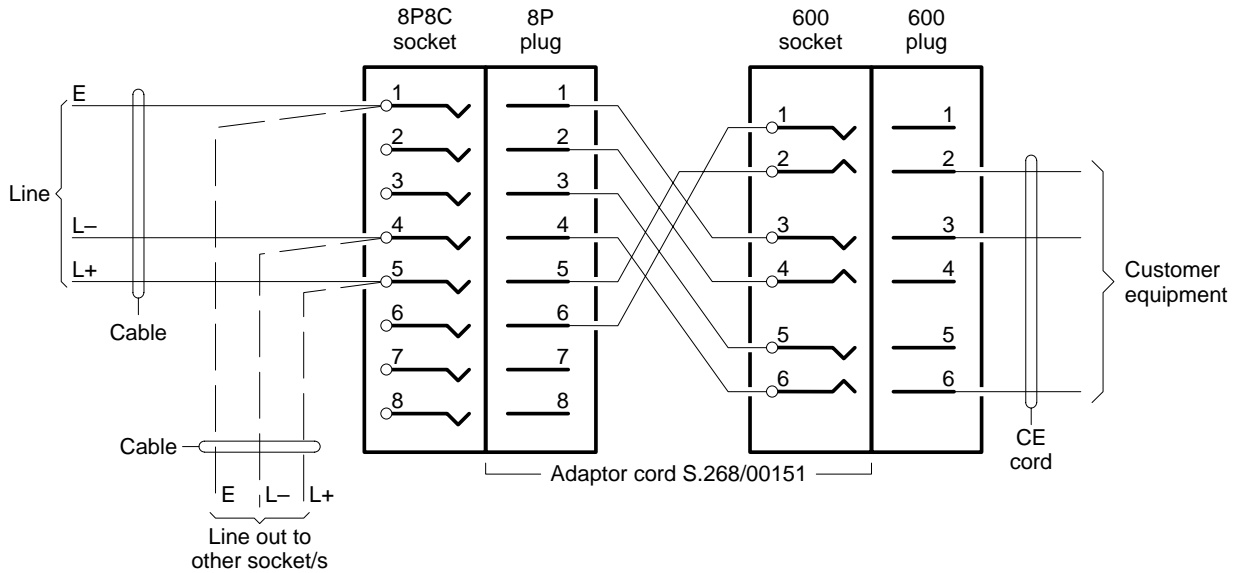

Note: The equivalent standard connection mode per Attachment A01 is mode 81A.

**Mode M 3 2-wire line, no earth, customer equipment switching, monitoring or tone injection on both legs, both legs switched through on removal of plug**

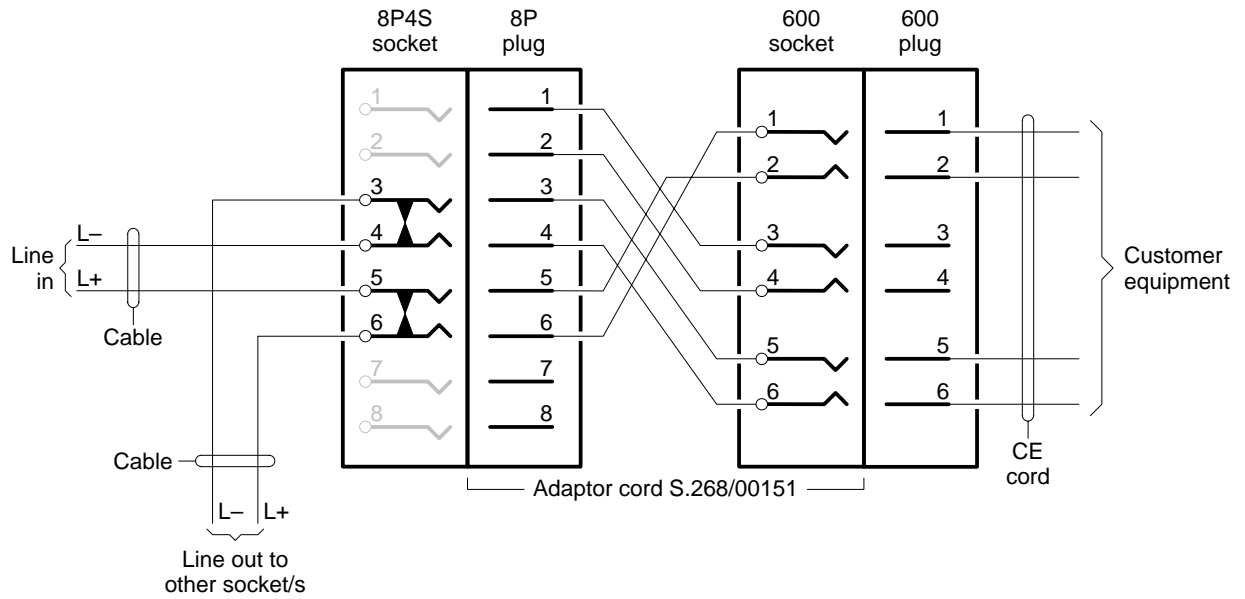

Note: The equivalent standard connection mode per Attachment A01 is mode 83A.

## Mode M 4 2-wire line with earth, customer equipment switching, monitoring or tone injection on both legs

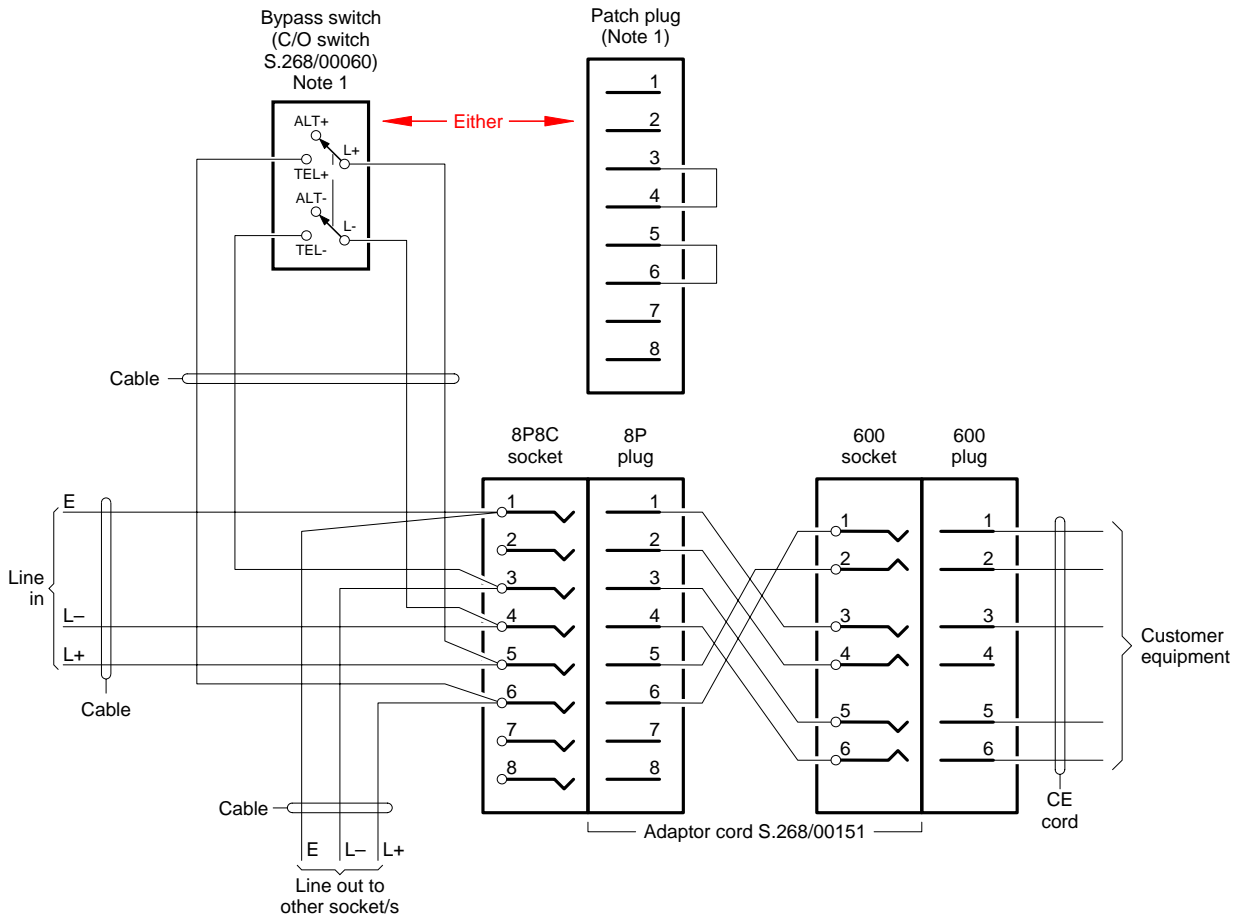

### Notes:

- Legs L+ and L- are connected through to other socket/s via circuitry in the customer equipment. If the line needs to be extended to other sockets when the customer equipment is unplugged, socket contacts 3 & 4 and 5 & 6 must be bridged by one of the following methods:
  - insertion of wire straps in the socket (must be done by a licensed cabler);
  - operation of a bypass switch wired as shown; or
  - insertion of a patch plug in place of the customer equipment plug.
 Where a patch plug is used, it can be "parked" in an adjacent, unterminated socket (ie. dual socket installation) with each socket suitably labelled (eg. "EQUIPMENT" and "PATCH PLUG").
- The equivalent standard connection mode per Attachment A01 is:
  - mode 84B (no socket switching); or
  - mode 84K (using patch plug); or
  - mode 86A (using switching socket); or
  - mode 87A (using switching socket); or
  - mode 89E (using manual bypass switch).

**Mode M 5 2-wire line, no earth, customer equipment switching, monitoring or tone injection on one leg, leg switched through on removal of plug**

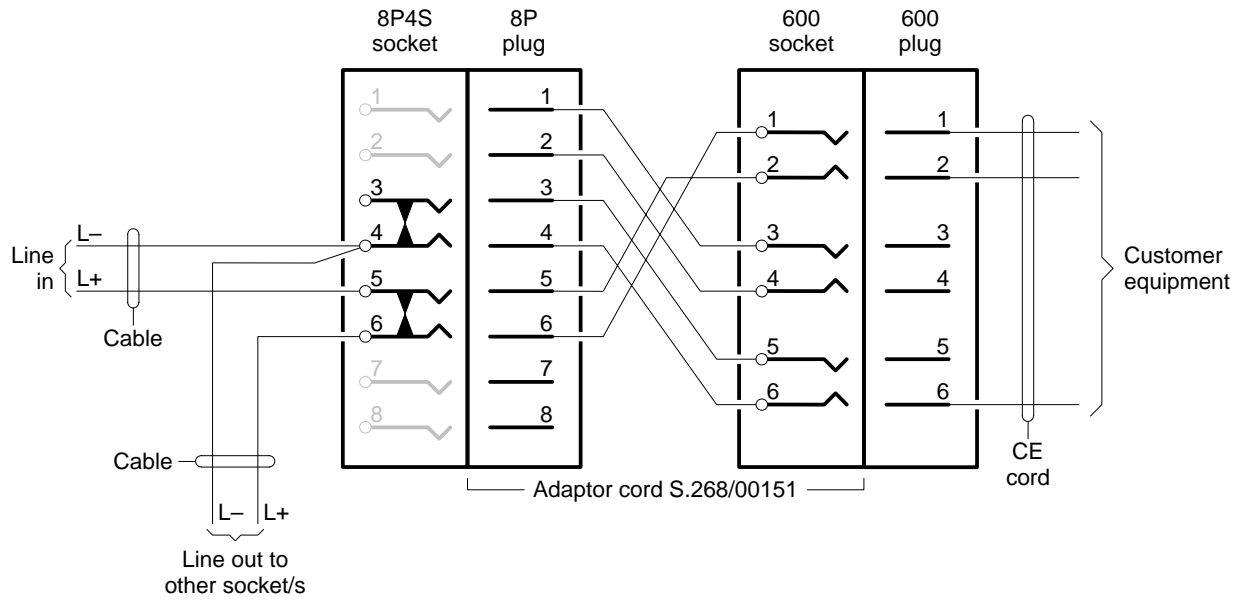

Note: The equivalent standard connection mode per Attachment A01 is mode 83A.

**Mode M 6 2-wire line with earth, customer equipment switching, monitoring or tone injection on one leg, leg switched through on removal of plug**

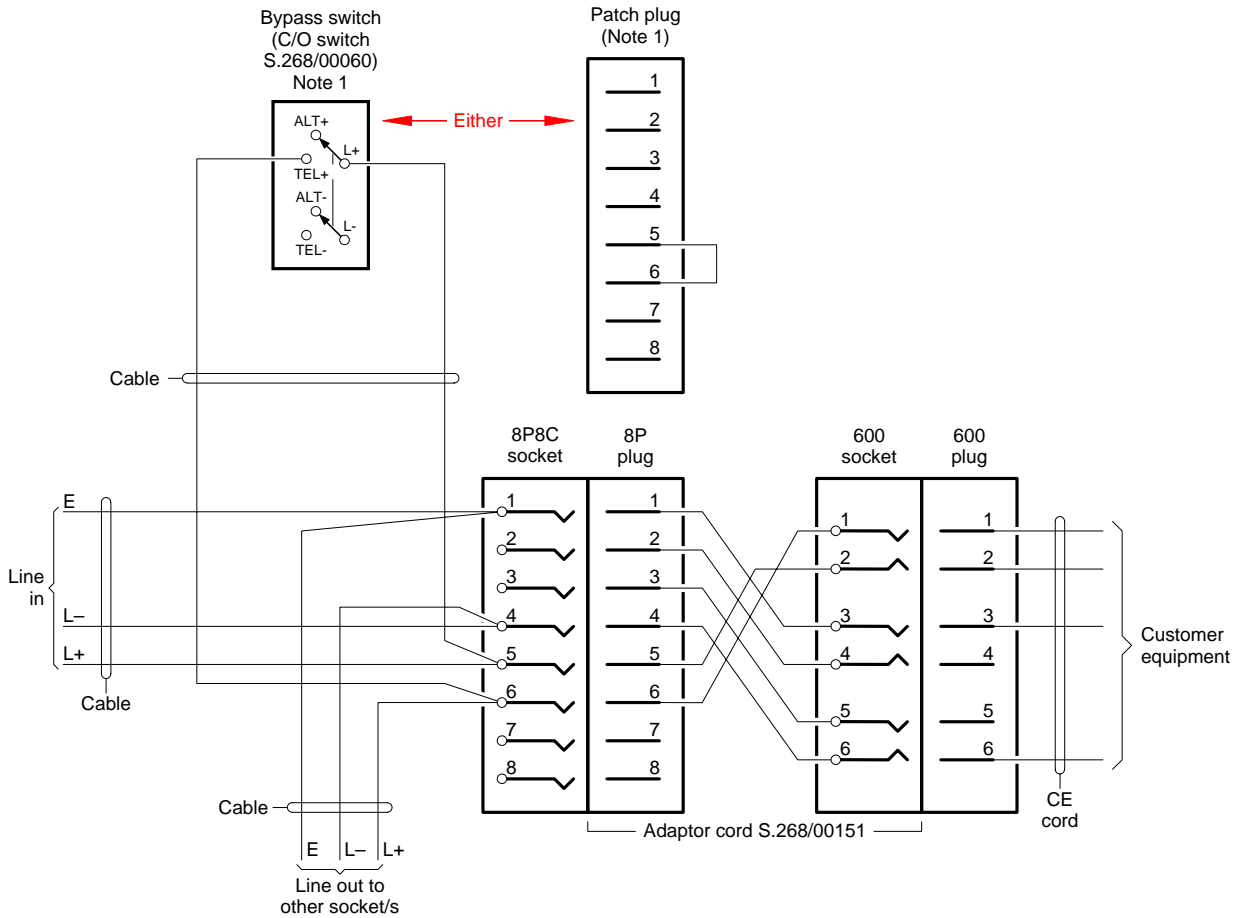

**Notes:**

1. Leg L+ is connected through to other socket/s via circuitry in the customer equipment. If the line needs to be extended to other sockets when the customer equipment is unplugged, socket contacts 5 & 6 must be bridged by one of the following methods:

- insertion of a wire strap in the socket (must be done by a licensed cabler);
- operation of a bypass switch wired as shown; or
- insertion of a patch plug in place of the customer equipment plug.

Where a patch plug is used, it can be “parked” in an adjacent, unterminated socket (ie. dual socket installation) with each socket suitably labelled (eg. “EQUIPMENT” and “PATCH PLUG”).

2. The equivalent standard connection mode per Attachment A01 is:

- mode 84B (no socket switching); or
- mode 84K (using patch plug); or
- mode 86A (using switching socket); or
- mode 87A (using switching socket); or
- mode 89E (using manual bypass switch).

**Mode M 7 2-wire line, manual switching of both legs via changeover (C/O) switch**

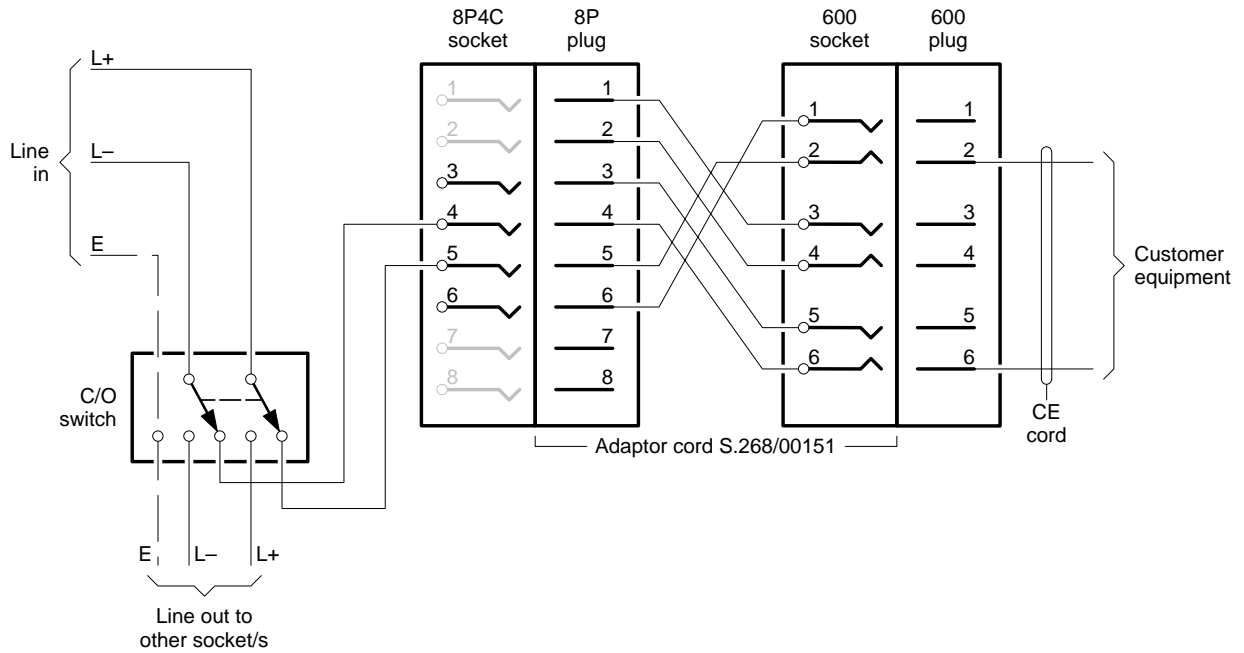

Notes:

1. If earth, TRC or CES connection is required at other socket/s, connect as shown thus - - - - -.
2. The equivalent standard connection mode per Attachment A01 is mode 88A.

**Mode M 8 2-wire line with earth, manual switching of both legs via changeover (C/O) switch**

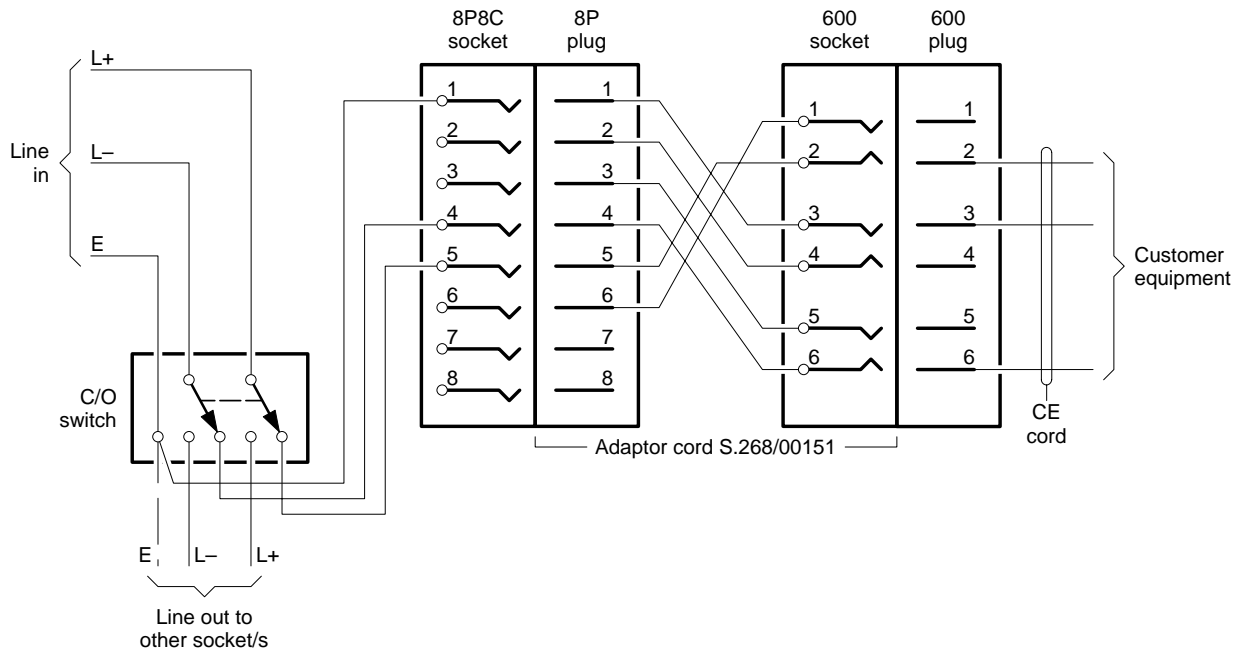

Notes:

1. If earth, TRC or CES connection is required at other socket/s, connect as shown thus - - - - -.
2. The equivalent standard connection mode per Attachment A01 is mode 88A.

## Mode M 9 2-wire line with optional earth, customer equipment switching, monitoring or tone injection on one leg, plus power feed

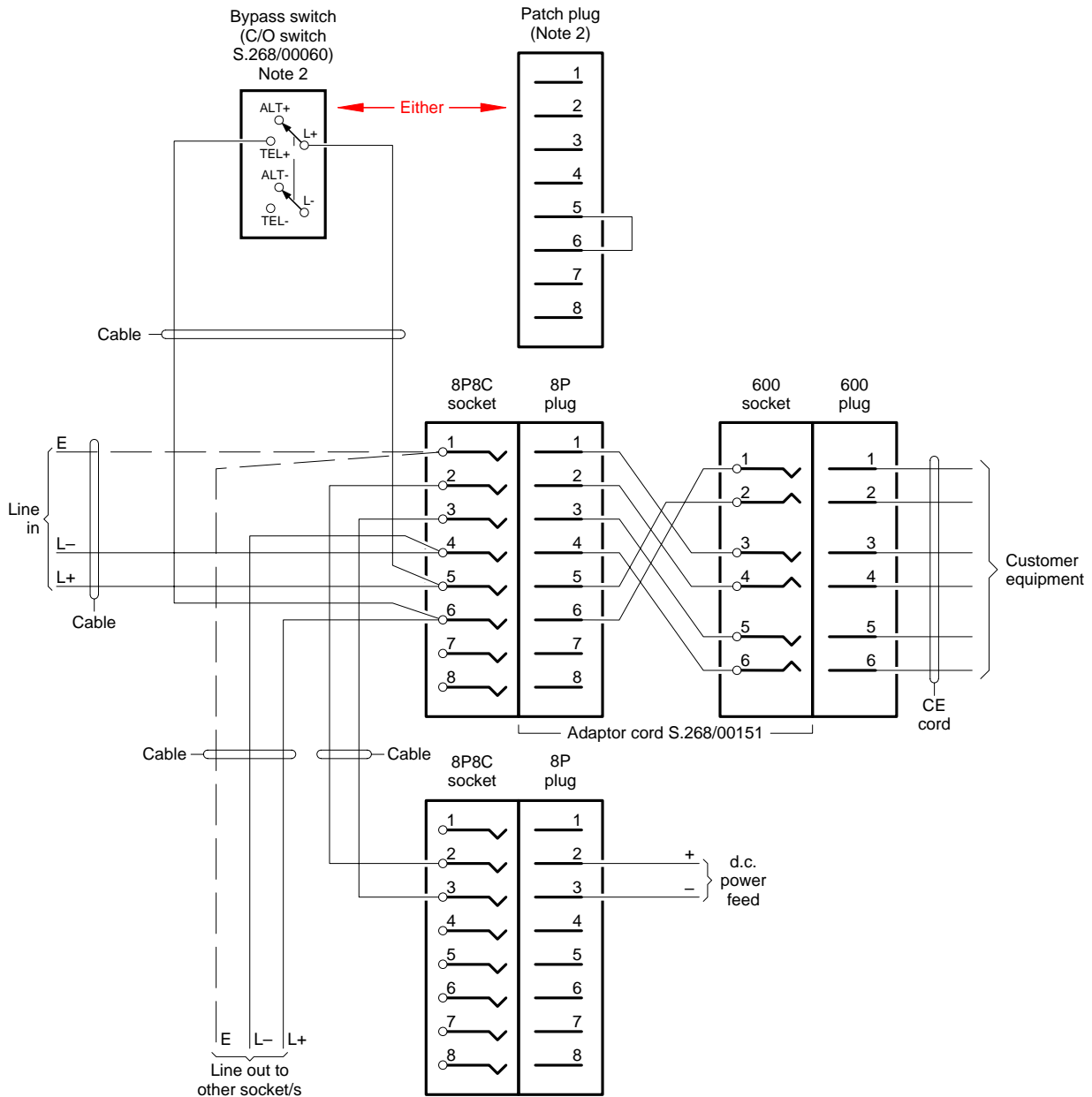

**Notes:**

1. If earth, TRC or CES connection is required, connect as shown thus - - - - -.
2. Leg L+ is connected through to other socket/s via circuitry in the customer equipment. If the line needs to be extended to other sockets when the customer equipment is unplugged, socket contacts 5 & 6 must be bridged by one of the following methods:
  - insertion of a wire strap in the socket (must be done by a licensed cabler);
  - operation of a bypass switch wired as shown; or
  - insertion of a patch plug in place of the customer equipment plug.
 Where a patch plug is used, it can be "parked" in an adjacent, unterminated socket (ie. dual socket installation) with each socket suitably labelled (eg. "EQUIPMENT" and "PATCH PLUG").
3. This mode was originally used for connection of a conversation recorder connector ("pip" tone generator).
4. The equivalent standard connection mode per Attachment A01 is:
  - mode 85C (no socket switching); or
  - mode 85M (using patch plug); or
  - mode 86K (using switching socket).

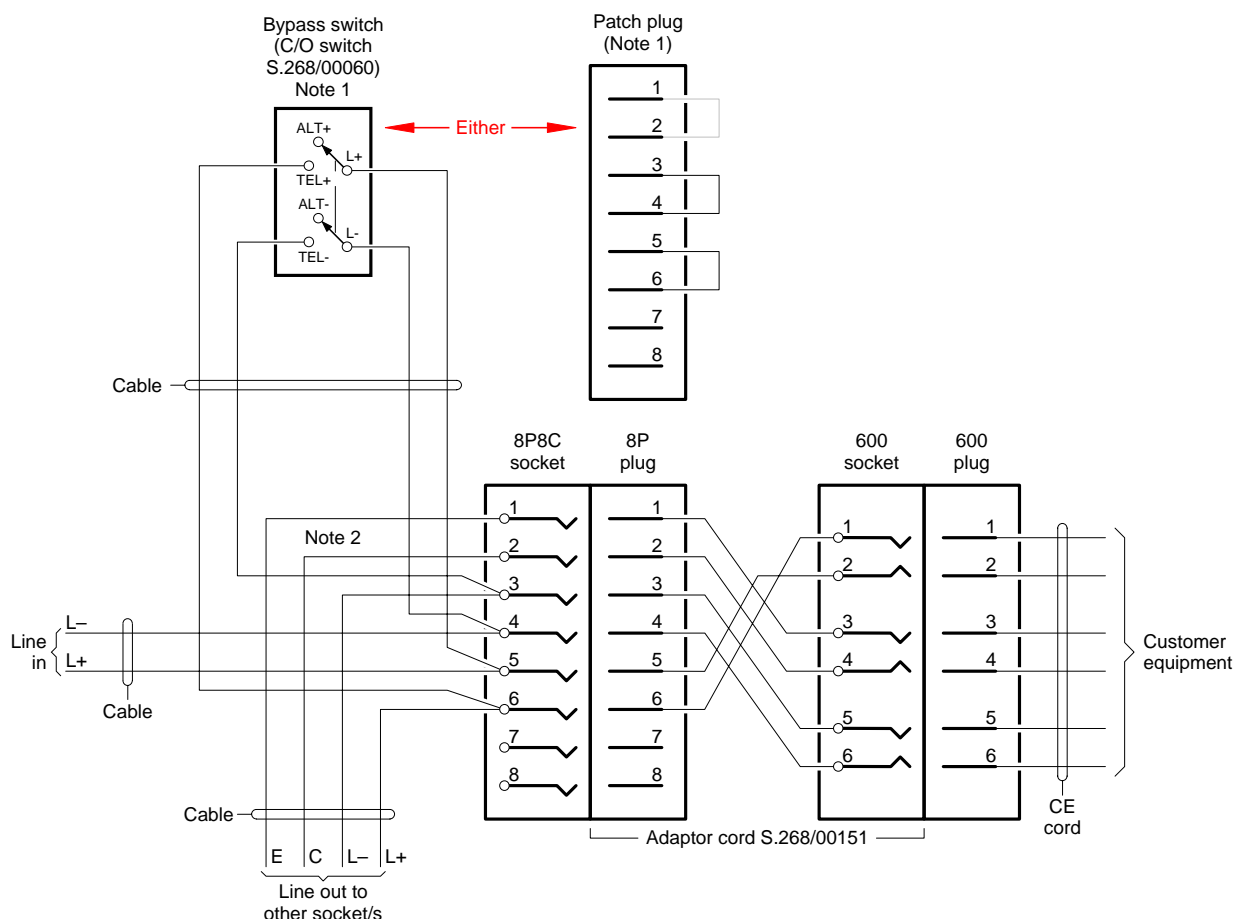
**Mode M 10    Use Mode M 3****Mode M 11    2-wire line, customer equipment switching, monitoring or tone injection on both legs, plus equipment control leads****Notes:**

- Legs L+ and L- are connected through to other socket/s via circuitry in the customer equipment. If the line needs to be extended to other sockets when the customer equipment is unplugged, socket contacts 3 & 4 and 5 & 6 must be bridged by one of the following methods:
  - insertion of wire straps in the socket (must be done by a licensed cabler);
  - operation of a bypass switch wired as shown; or
  - insertion of a patch plug in place of the customer equipment plug.
 Where a patch plug is used, it can be "parked" in an adjacent, unterminated socket (ie. dual socket installation) with each socket suitably labelled (eg. "EQUIPMENT" and "PATCH PLUG").
- Leads C and E are control or supervisory leads.
- The equivalent standard connection mode per Attachment A01 is:
  - mode 85B (no socket switching); or
  - mode 85L (using patch plug); or
  - mode 86J (using switching socket).

## Mode M 12 2-wire line, non-standard connection

### (a) Voice line

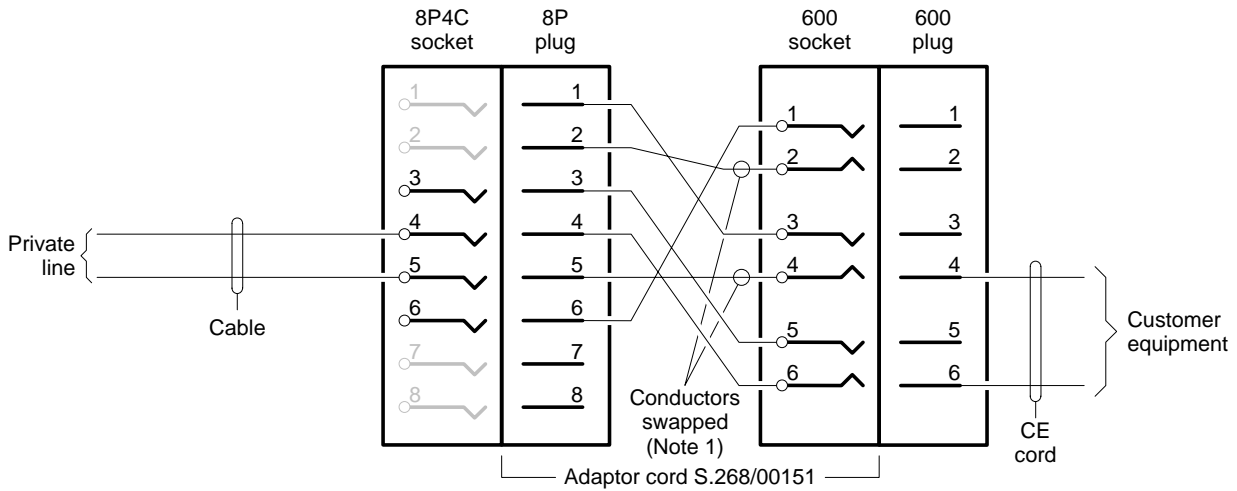

Notes:

1. In the 600 socket of the adaptor cord, swap over the cord conductors on terminals 2 and 4. Mark the rear of the socket, "NON-STANDARD — CORD TRANSPOSED ON 2 & 4".
2. The type of socket used may be 8P4C or 8P8C. By changing the line connection to socket terminals 4 & 5 (and modifying the adaptor cord) as shown, this ensures the equipment can be connected via integrated cabling to AS/NZS 3080 using the existing wiring and 8P8C socket.
3. The equivalent standard connection mode per Attachment A01 is mode 81A or 81D.

### (b) Data line

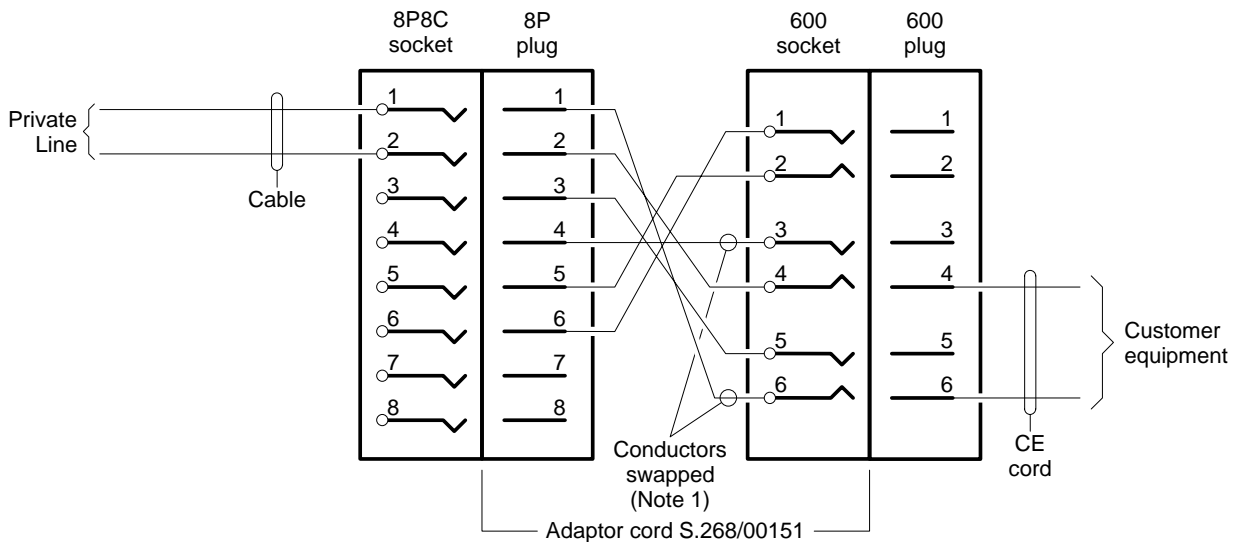

Notes:

1. In the 600 socket of the adaptor cord, swap over the cord conductors on terminals 3 and 6. Mark the rear of the socket, "NON-STANDARD — CORD TRANSPOSED ON 3 & 6". Alternatively, use DDN adaptor cord S.511/00253.
2. By changing the line 1/line 2 connection to balanced (rather than split) pairs and modifying the adaptor cord as shown, this ensures the equipment can be connected via integrated cabling to AS/NZS 3080 using the existing wiring and 8P8C socket.
3. The equivalent standard connection mode per Attachment A01 is mode 84F.

**Mode M 13 2-wire line with earth, non-standard connection**

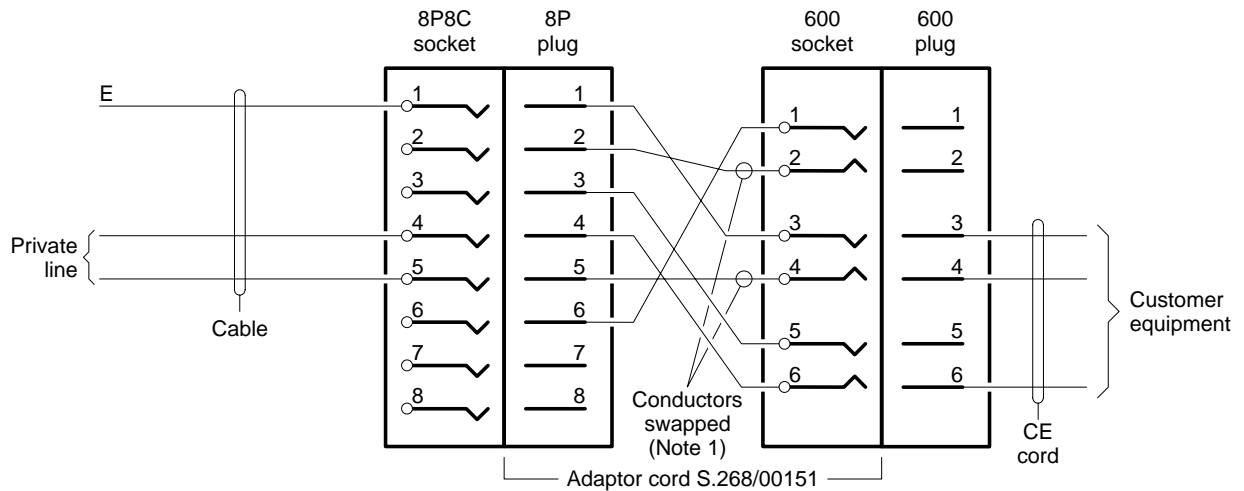

**Notes:**

1. In the 600 socket of the adaptor cord, swap over the cord conductors on terminals 2 and 4. Mark the rear of the socket, "NON-STANDARD — CORD TRANSPOSED ON 2 & 4".
2. By changing the line connection to socket terminals 4 & 5 (and modifying the adaptor cord) as shown, this ensures the equipment can be connected via integrated cabling to AS/NZS 3080 using the existing wiring and 8P8C socket.
3. The equivalent standard connection mode per Attachment A01 is mode 81A.

**Mode M 14 2-wire line, non-standard connection, diode test termination**

**(a) With diode test termination**

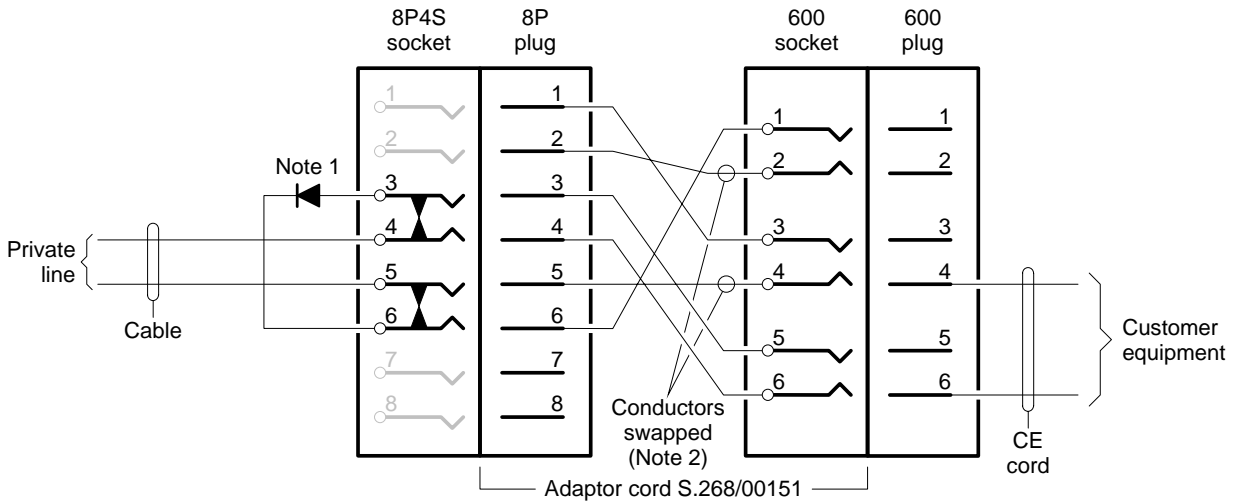

**Notes:**

1. Use diode general purpose type 1N4004 (400V/1A) or 1N4007 (1000V/1A) connected directly to the socket IDC terminals.
2. In the 600 socket of the adaptor cord, swap over the cord conductors on terminals 2 and 4. Mark the rear of the socket, "NON-STANDARD — CORD TRANSPOSED ON 2 & 4".
3. Where the equipment is to be connected via integrated cabling to AS/NZS 3080 using the existing wiring and 8P8C socket, the diode termination must be foregone and the equipment connected as a mode M 12.
4. The equivalent standard connection mode per Attachment A01 is mode 83C.

**(b) Diode test termination foregone in favour of data line connection method**

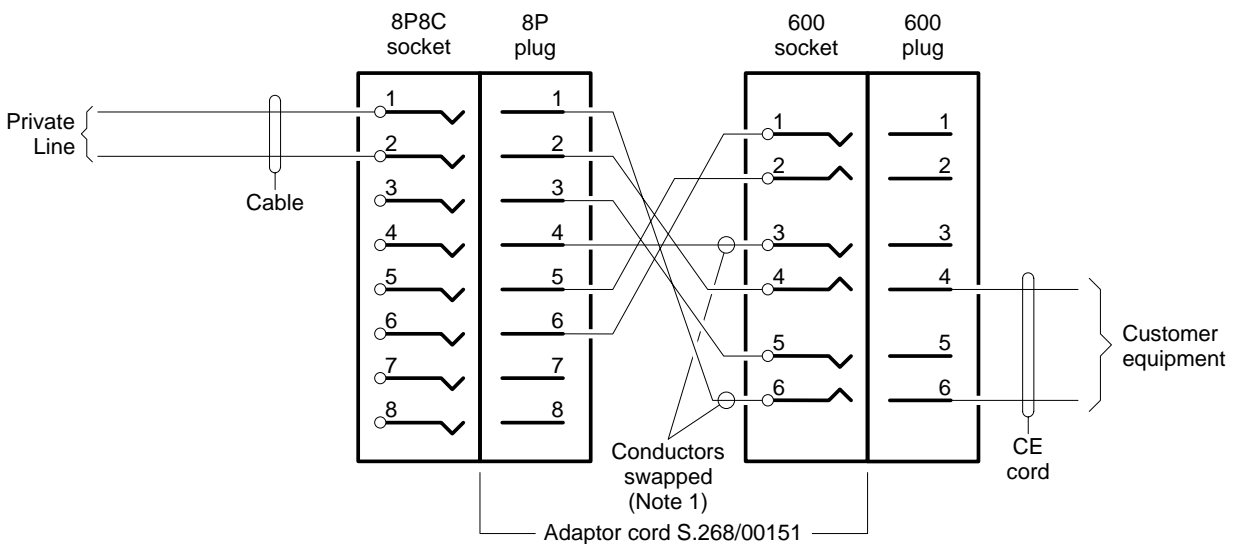

**Notes:**

1. In the 600 socket of the adaptor cord, swap over the cord conductors on terminals 3 and 6. Mark the rear of the socket, "NON-STANDARD — CORD TRANSPOSED ON 3 & 6". Alternatively, use DDN adaptor cord S.511/00253.
2. By changing the line 1/line 2 connection to balanced (rather than split) pairs and modifying the adaptor cord as shown, this ensures the equipment can be connected via integrated cabling to AS/NZS 3080 using the existing wiring and 8P8C socket.
3. This is the same as mode M 12(b). The equivalent standard connection mode per Attachment A01 is mode 84F.

## Mode M 15 2-wire line with earth, non-standard connection, diode test termination

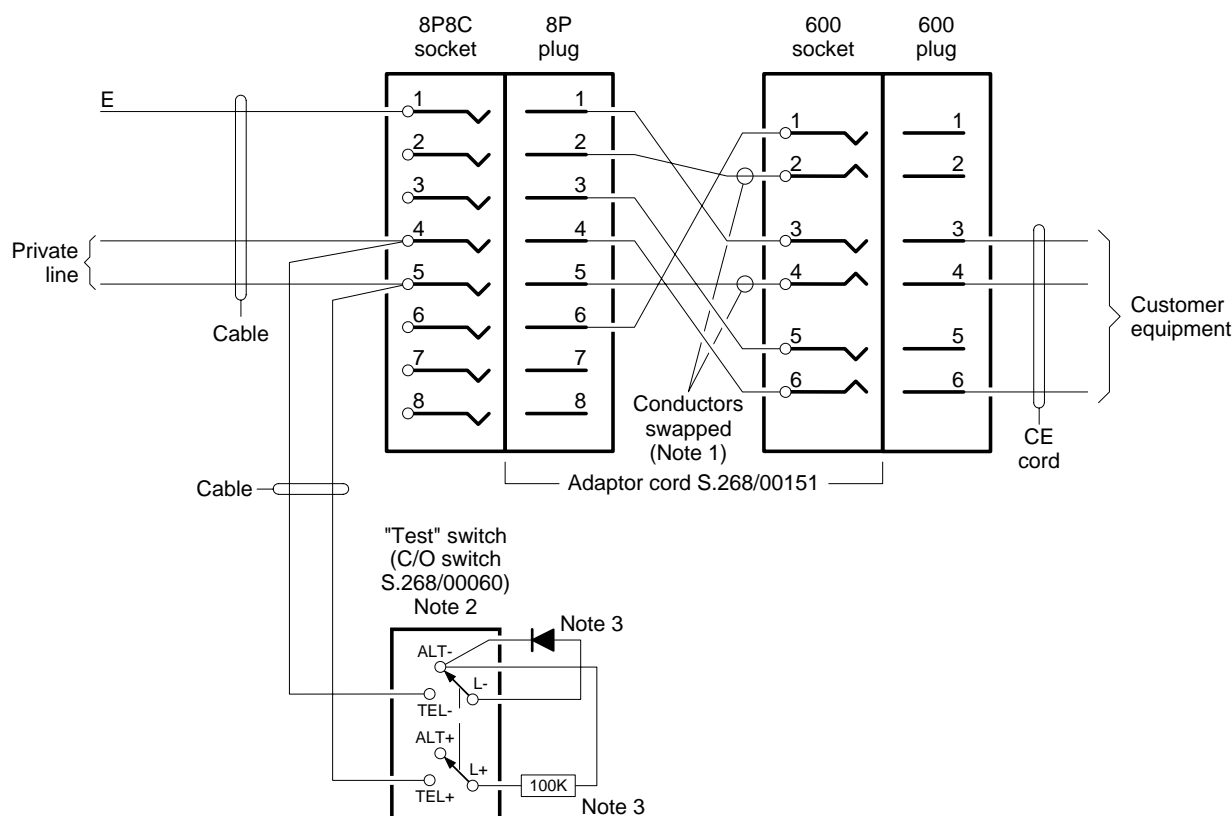

### Notes:

- In the 600 socket of the adaptor cord, swap over the cord conductors on terminals 2 and 4. Mark the rear of the socket, "NON-STANDARD — CORD TRANSPOSED ON 2 & 4".
- With this wiring configuration, a test termination is achieved manually by operation of a C/O switch wired as shown. The switch should be suitably labelled (eg. "NORMAL" and "TEST"). Where the switch and diode circuit cannot be justified, use mode M 13 or M 14(b).
- Use diode general purpose type 1N4004 (400V/1A) or 1N4007 (1000V/1A) and 100k (¼W) resistor connected to the switch screw terminals as shown. A diode/resistor termination is used to avoid short-circuiting the line if the switch is accidentally operated during normal service.
- Where the equipment is to be connected via integrated cabling to AS/NZS 3080 using the existing wiring and 8P8C socket, the switch and diode termination must be foregone and the equipment connected as a mode M 13 or M 14(b).
- The equivalent standard connection mode per Attachment A01 is:
  - mode 81B (voice line termination using test plug); or
  - mode 84F (data line with test termination foregone); or
  - mode 86C (using switching socket); or
  - mode 87C (using switching socket); or
  - mode 88C (using manual test switch).

## Mode M 16 Two 2-wire lines or 4-wire line

### (a) Quick fix

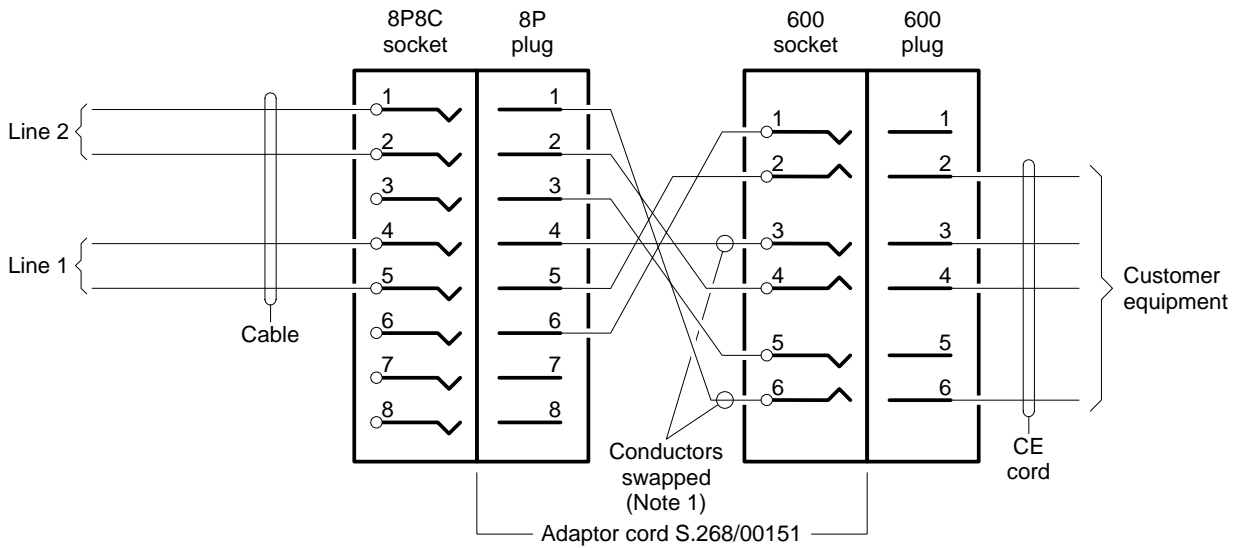

#### Notes:

1. In the 600 socket of the adaptor cord, swap over the cord conductors on terminals 3 and 6. Mark the rear of the socket, "NON-STANDARD — CORD TRANSPOSED ON 3 & 6". Alternatively, use DDN adaptor cord S.511/00253.
2. By changing the line 1/line 2 connection to balanced (rather than split) pairs and modifying the adaptor cord as shown, this ensures the equipment can be connected via integrated cabling to AS/NZS 3080 using the existing wiring and 8P8C socket.
3. The equivalent standard connection mode per Attachment A01 is mode 84G. The recommended standard connection mode is mode 84N (see "Permanent fix" below).

### (b) Permanent fix

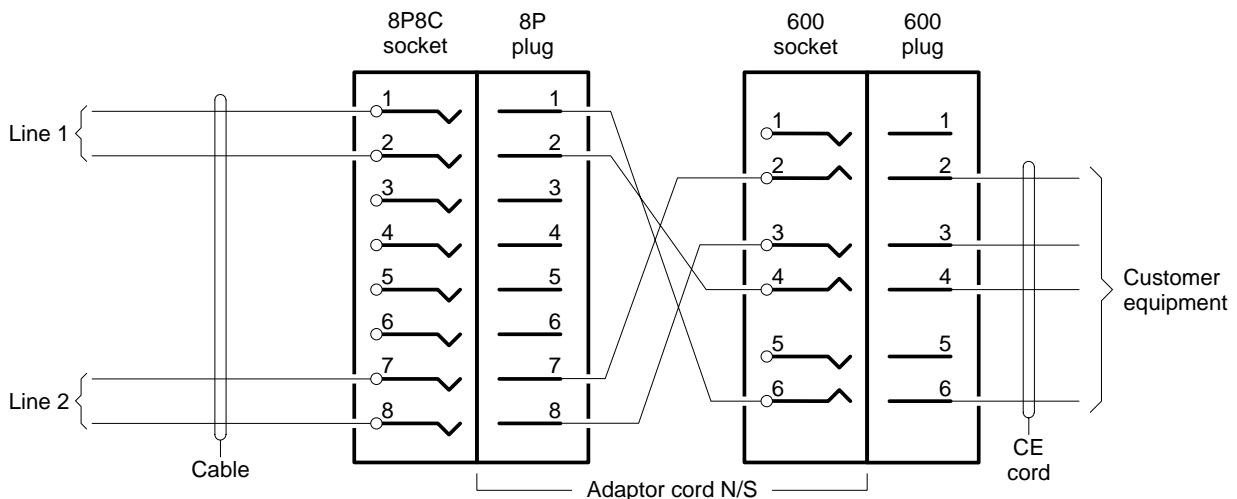

#### Notes:

1. This wiring arrangement requires the manufacture of a new adaptor cord. The equipment can be connected via integrated cabling to AS/NZS 3080 using the existing wiring and 8P8C socket.
2. The advantage of this wiring arrangement (ie. using contacts 1 & 2 and 7 & 8) is that it is the same line connection as mode 86H/87H per Attachment A01 which supports diode test termination on both lines on withdrawal of the plug.
3. The equivalent standard connection mode per Attachment A01 is mode 84N.

## Mode M 17 4-wire line, diode test termination, manual test switch

### (a) Quick fix

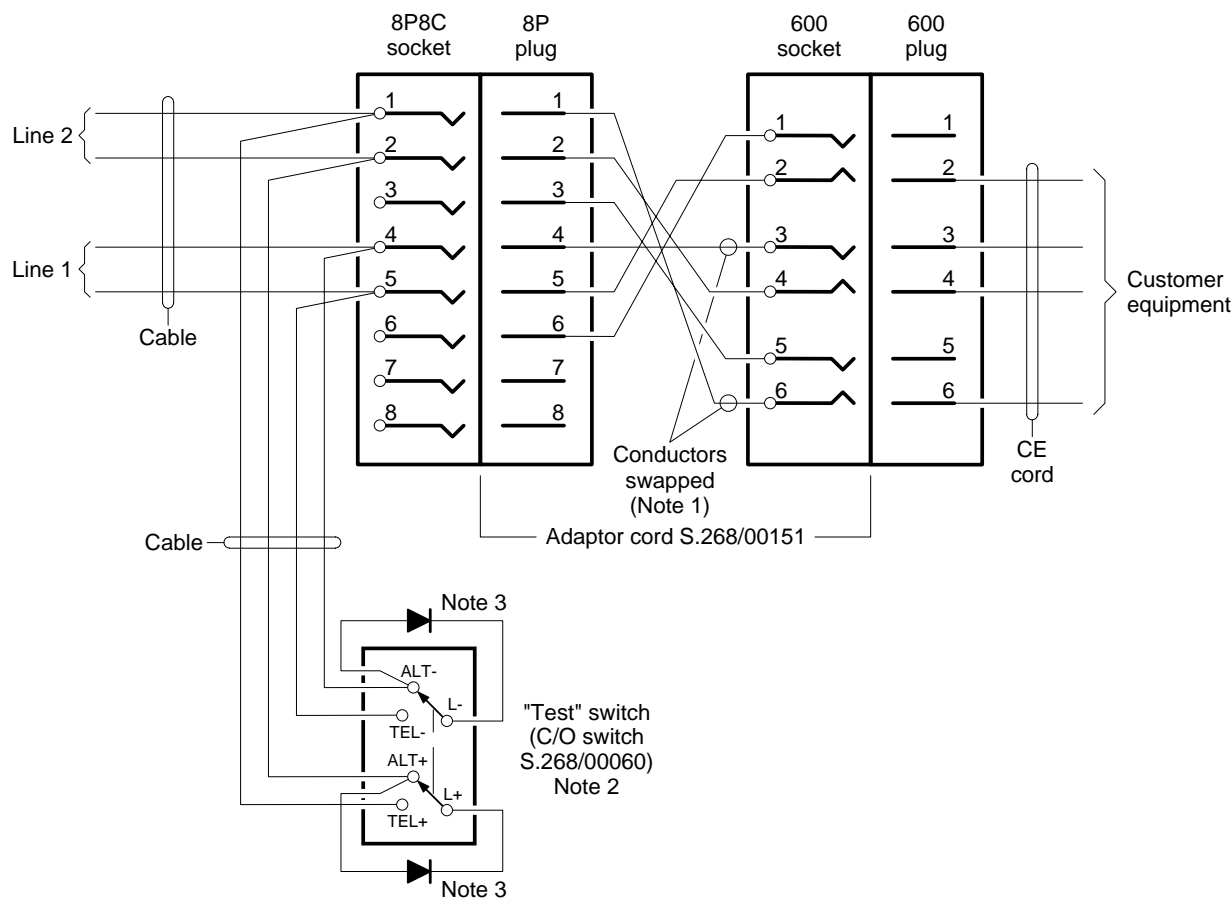

#### Notes:

1. In the 600 socket of the adaptor cord, swap over the cord conductors on terminals 3 and 6. Mark the rear of the socket, "NON-STANDARD — CORD TRANSPOSED ON 3 & 6". Alternatively, use DDN adaptor cord S.511/00253.
2. With this wiring configuration, a test termination is achieved manually by operation of a C/O switch wired as shown. The switch should be suitably labelled (eg. "NORMAL" and "TEST"). Where the switch and diodes cannot be justified, use mode M 16(a).
3. Use diode general purpose type 1N4004 (400V/1A) or 1N4007 (1000V/1A) connected to the switch screw terminals as shown.
4. By changing the line 1/line 2 connection to balanced (rather than split) pairs and modifying the adaptor cord as shown, this ensures the equipment can be connected via integrated cabling to AS/NZS 3080 using the existing wiring and 8P8C socket.
5. The equivalent standard connection mode per Attachment A01 is mode 84G (no test termination). The recommended standard connection mode per Attachment A01 is mode 84N (no test termination) or mode 86H or 87H (with test termination).

**Mode M 17 (continued)**

**(b) Permanent fix**

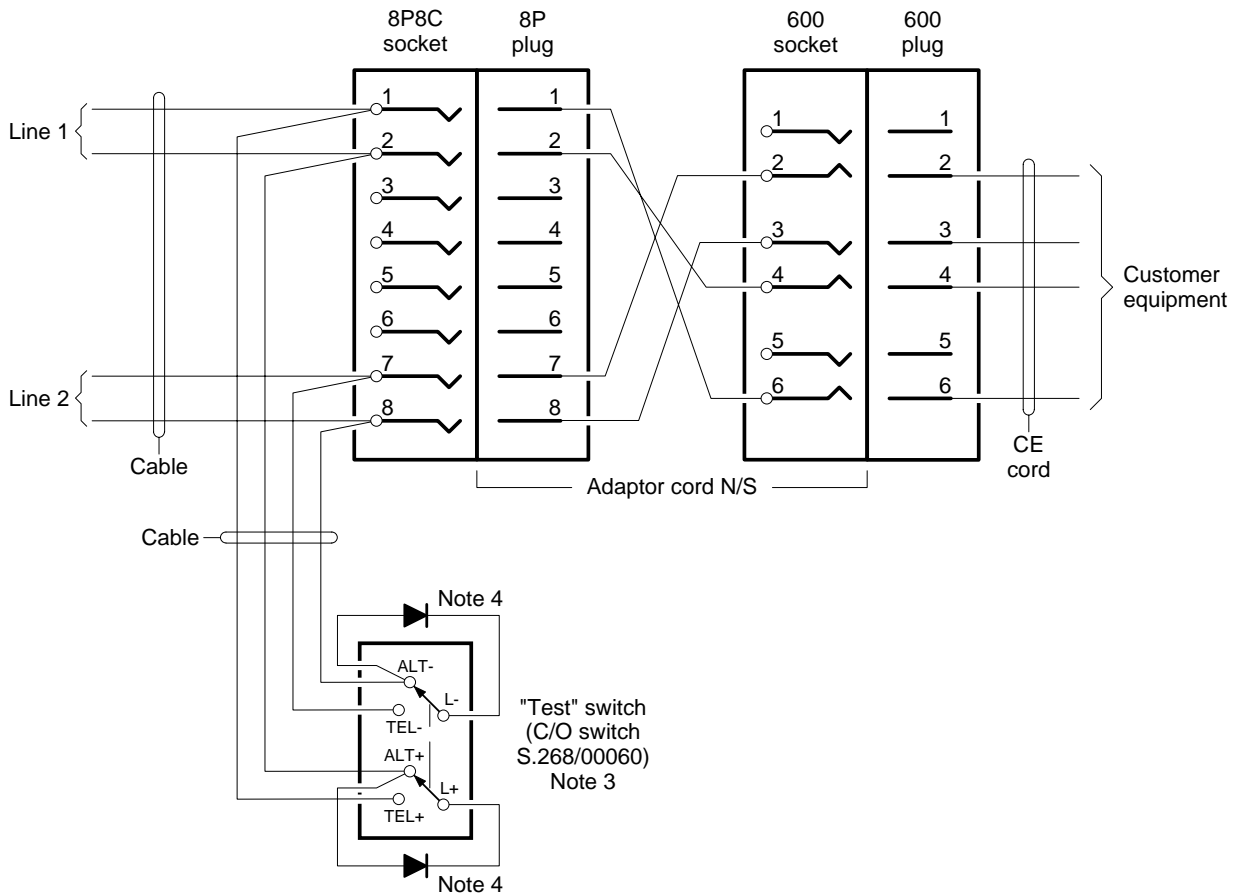

**Notes:**

1. This wiring arrangement requires the manufacture of a new adaptor cord. The equipment can be connected via integrated cabling to AS/NZS 3080 using the existing wiring and 8P8C socket.
2. The advantage of this wiring arrangement (ie. using contacts 1 & 2 and 7 & 8) is that it is the same line connection as mode 86H/87H per Attachment A01 which supports diode test termination on both lines on withdrawal of the plug.
3. With this wiring configuration, a test termination is achieved manually by operation of a C/O switch wired as shown. The switch should be suitably labelled (eg. "NORMAL" and "TEST"). Where the switch and diodes cannot be justified, use mode M 16(b).
4. Use diode general purpose type 1N4004 (400V/1A) or 1N4007 (1000V/1A) connected to the switch screw terminals as shown.
5. The equivalent standard connection mode per Attachment A01 is mode 84N (no test termination) or mode 86H or 87H (with test termination).

## Mode M 18 2-wire line with optional earth, manual switching of both legs via changeover (C/O) switch to either standard customer equipment or customer equipment with power feed and switching, monitoring or tone injection on one leg

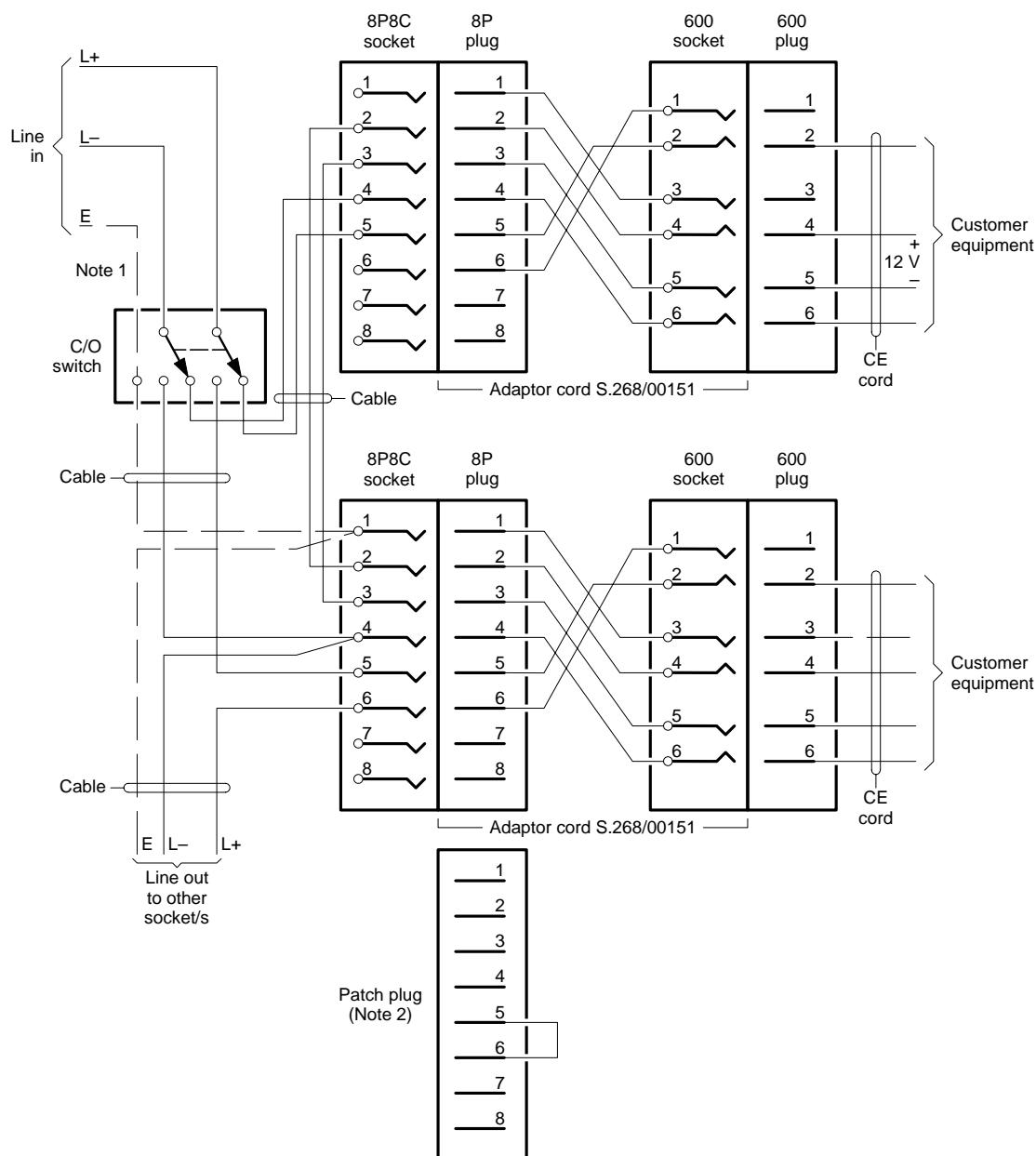

### Notes:

1. If earth, TRC or CES connection is required, connect as shown thus - - - - -.
2. Leg L+ is connected through to other socket/s via circuitry in the customer equipment. If the line needs to be extended to other sockets when the customer equipment is unplugged, socket contacts 5 & 6 must be bridged by one of the following methods:
  - insertion of a wire strap in the socket (must be done by a licensed cabler);
  - operation of a bypass switch wired as shown in mode M 9; or
  - insertion of a patch plug in place of the customer equipment plug.
 Where a patch plug is used, it can be "parked" in an adjacent, unterminated socket with each socket suitably labelled (eg. "EQUIPMENT" and "PATCH PLUG").
3. This mode was originally used for connection of a conversation recorder connector ("pip" tone generator).
4. The equivalent standard connection mode per Attachment A01 is mode 88A with one or both TOs (sockets) terminated as mode 86K.

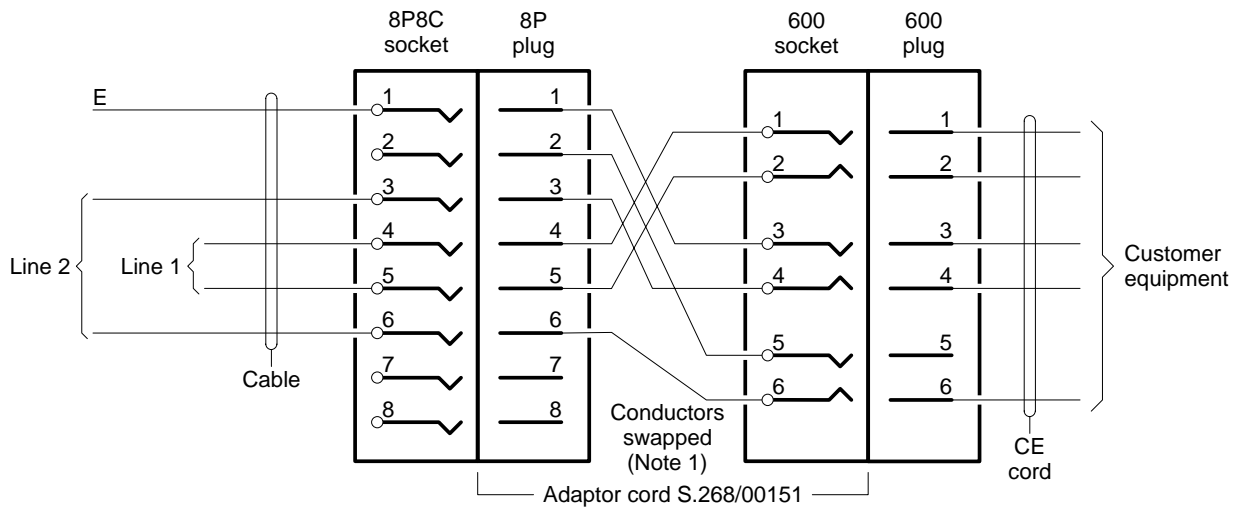
**Mode M 19 4-wire line with earth, non-standard connection****Notes:**

1. In the 600 socket of the adaptor cord, swap over the cord conductors on terminals 1 & 6 and 4 & 5. Mark the rear of the socket, "NON-STANDARD — CORD TRANSPOSED ON 1 & 6 AND 4 & 5".
2. By changing the line 1/line 2 connection to balanced (rather than split) pairs and modifying the adaptor cord as shown, this ensures the equipment can be connected via integrated cabling to AS/NZS 3080 using the existing wiring and 8P8C socket.
3. The equivalent standard connection mode per Attachment A01 is mode 84A.

**Mode M 20 4-wire line with loopback facility using dual plugs and sockets, non-standard connection**

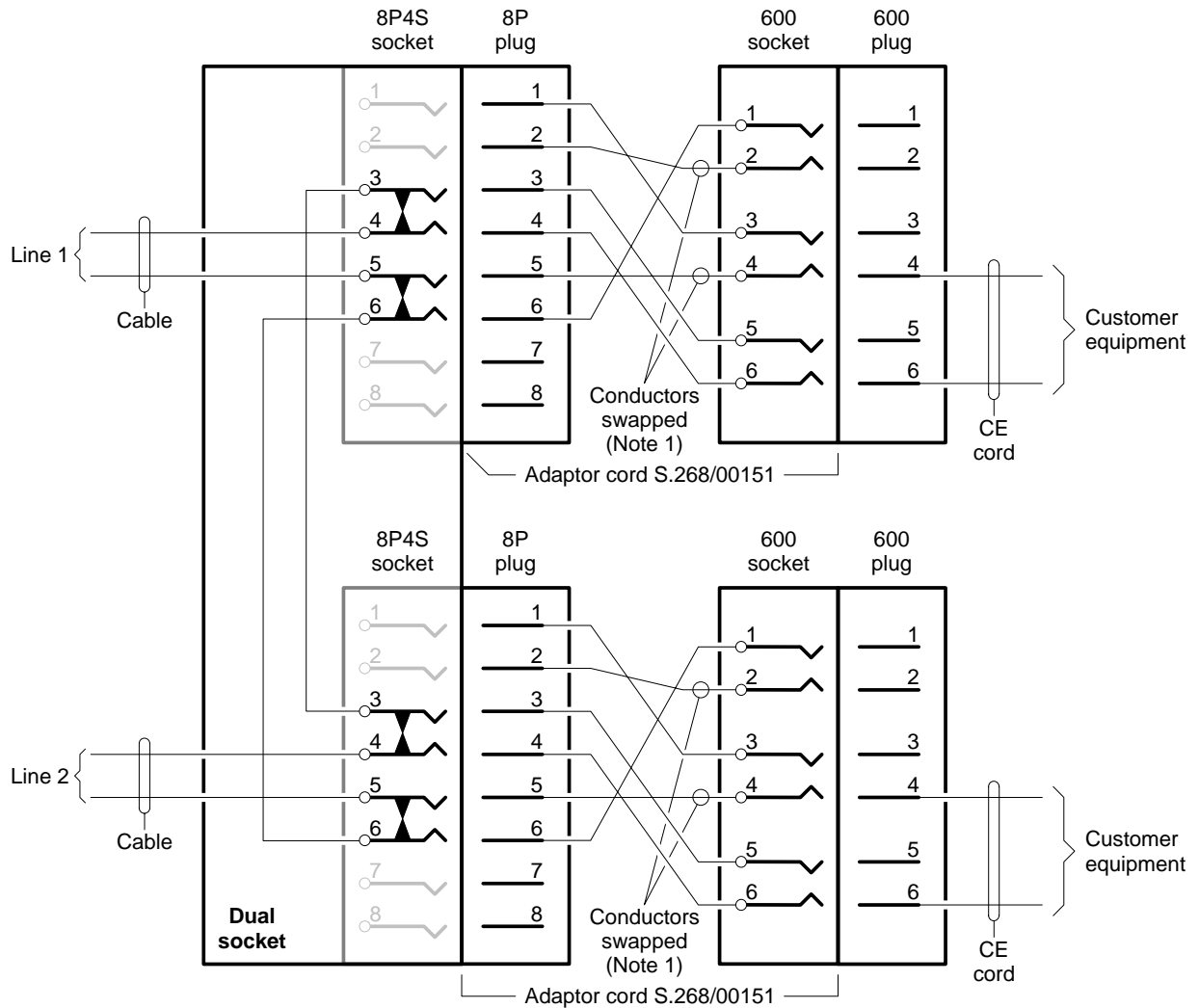

**Notes:**

1. In the 600 socket of the adaptor cord, swap over the cord conductors on terminals 2 and 4. Mark the rear of the socket, "NON-STANDARD — CORD TRANSPOSED ON 2 & 4".
2. The equivalent standard connection mode per Attachment A01 is mode 83F or 83G.

**Mode M 22 2-wire line, two modes M 3 in tandem**

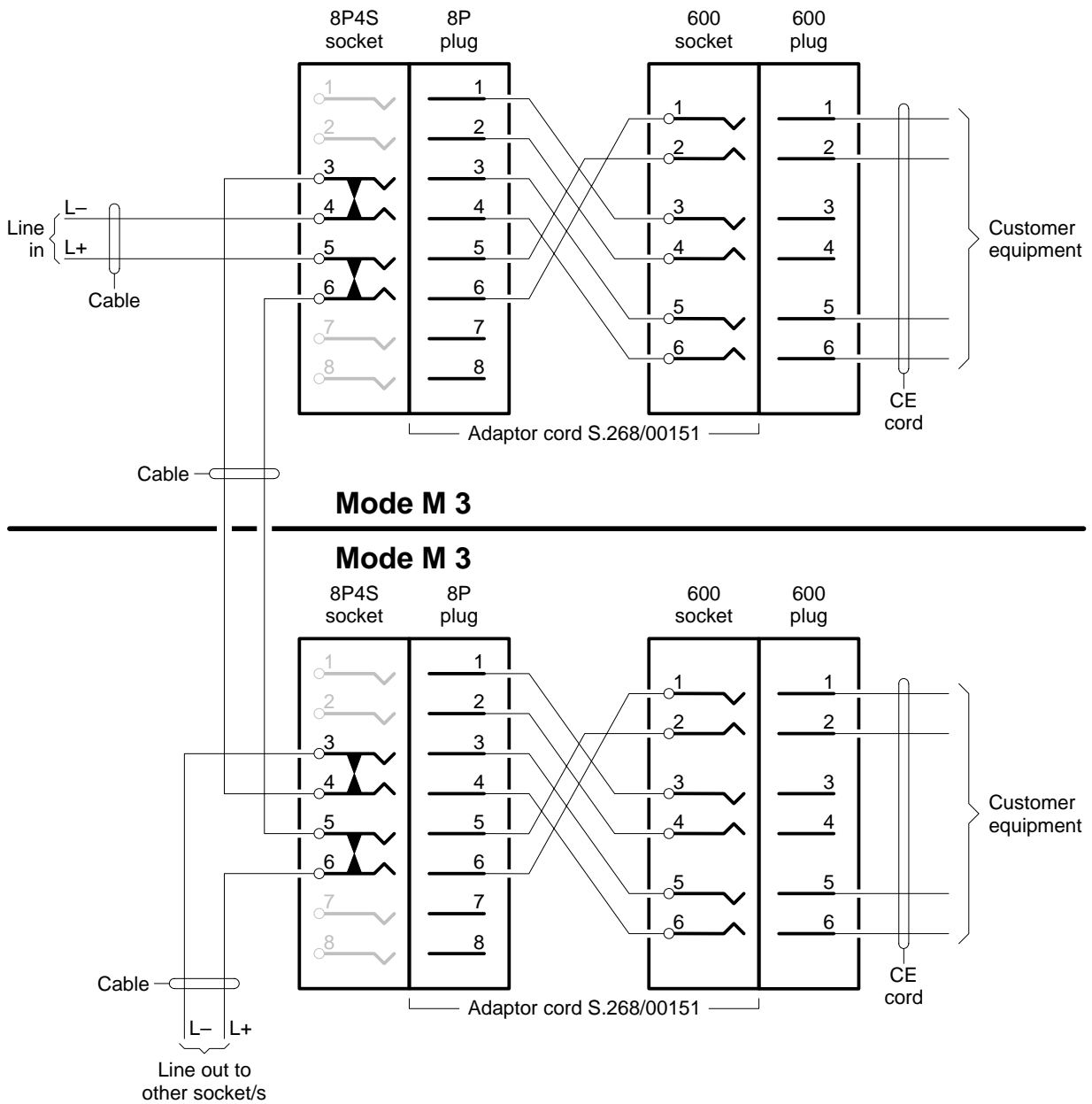

**Notes:**

1. This mode was originally used for connection of a manual answer Datel modem associated with automatic calling equipment (ACE).
2. The equivalent standard connection mode per Attachment A01 is mode 83B.

**Mode M 23 2-wire line, two modes M 11 in tandem**

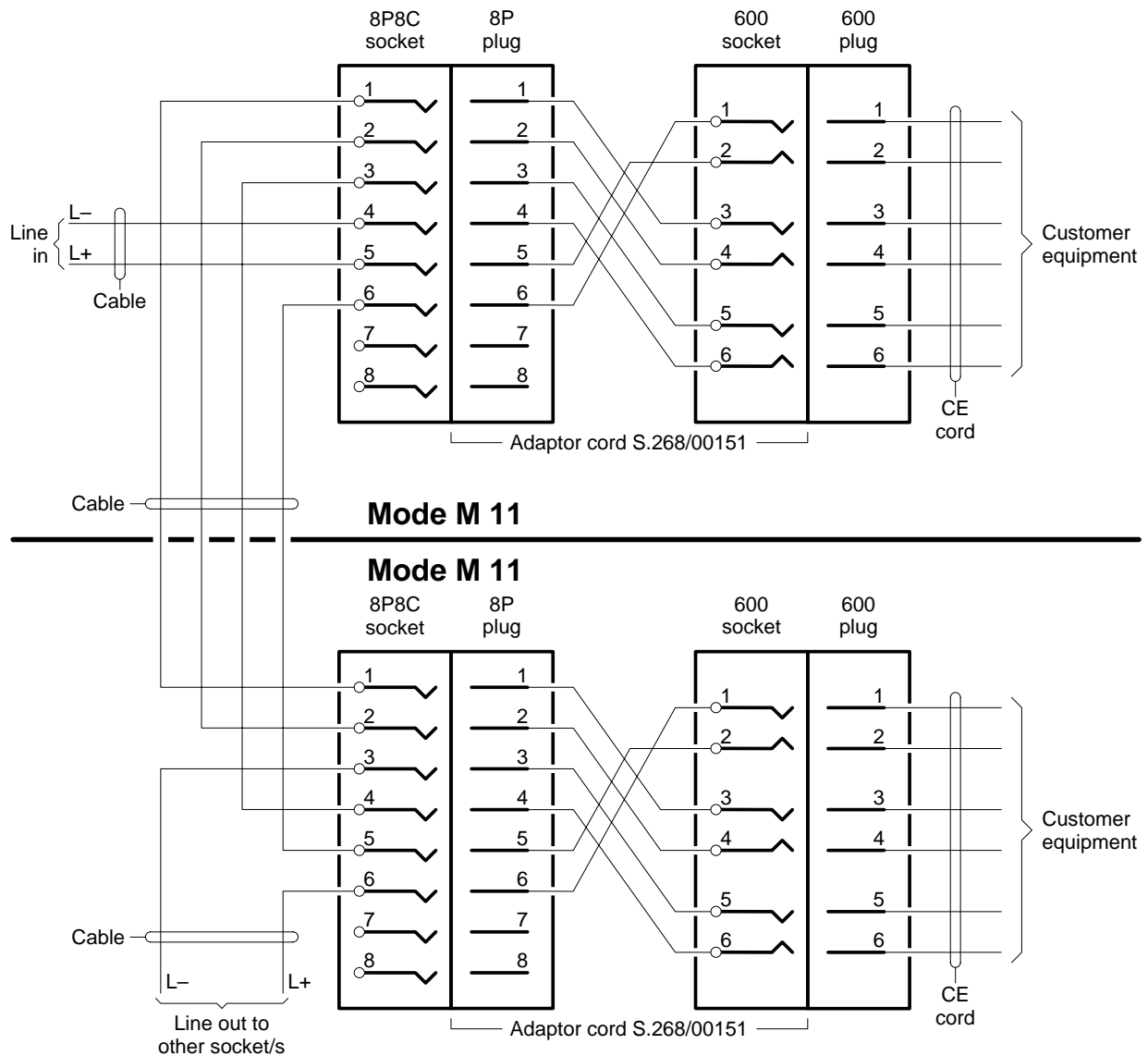

**Notes:**

1. Legs L+ and L- are connected through to other socket/s via circuitry in the customer equipment. If the line needs to be extended to other sockets when the customer equipment is unplugged, socket contacts 3 & 4 and 5 & 6 must be bridged by one of the following methods:
  - insertion of wire straps in the socket (must be done by a licensed cabler);
  - operation of a bypass switch wired as shown in mode M 11; or
  - insertion of a patch plug in place of the customer equipment plug.
 Where a patch plug is used, it can be "parked" in an adjacent, unterminated socket with each socket suitably labelled (eg. "EQUIPMENT" and "PATCH PLUG").
2. This mode was originally used for connection of an automatic answering Datel modem associated with automatic calling equipment (ACE).
3. The equivalent standard connection mode per Attachment A01 is:
  - 2 x mode 85B (no socket switching); or
  - 2 x mode 85L (using patch plug); or
  - 2 x mode 86J (using switching socket).

## Mode M 24 2-wire line, customer equipment switching, monitoring or tone injection on both legs, plus equipment control leads

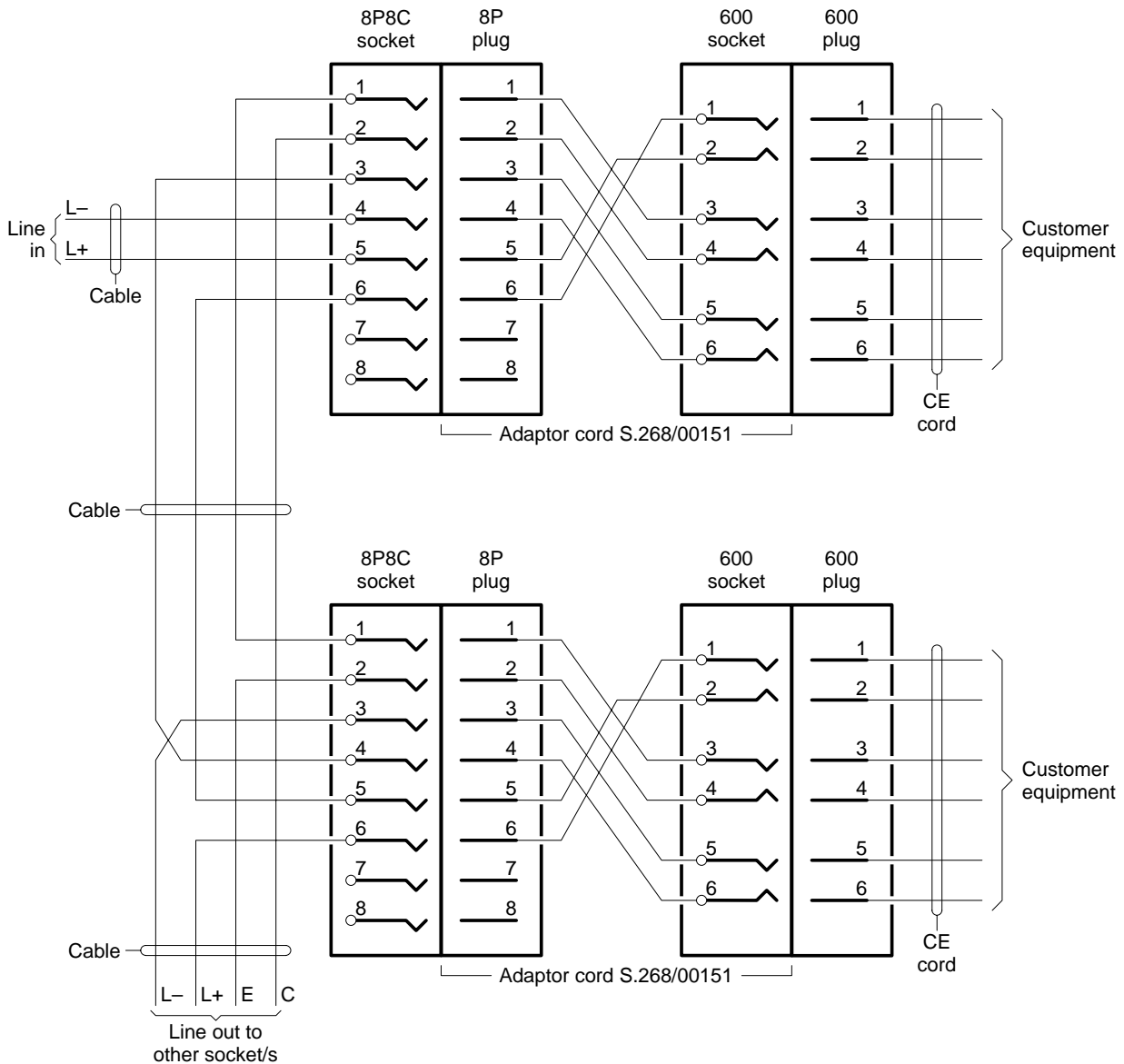

### Notes:

1. Legs L+ and L- and the control leads on terminals 1 & 2 are connected through to other socket/s via circuitry in the customer equipment. If the customer equipment is unplugged, socket contacts 1 & 2, 3 & 4 and 5 & 6 must be bridged either by insertion of a patch plug or wire straps in the socket to through-connect the line and control leads to the other sockets while the equipment is unplugged. The patch plug can be "parked" in an adjacent, unterminated socket (ie. dual socket installation) with each socket being suitably labelled (eg. "EQUIPMENT" and "PATCH PLUG").
2. This mode was originally used for connection of an automatic Datel modem with manual answer facilities associated with automatic calling equipment (ACE).
3. The equivalent standard connection mode per Attachment A01 is mode 86J.

**Mode M 25 2-wire line with optional earth, series ring detect facility and customer equipment switching, monitoring or tone injection on one leg**

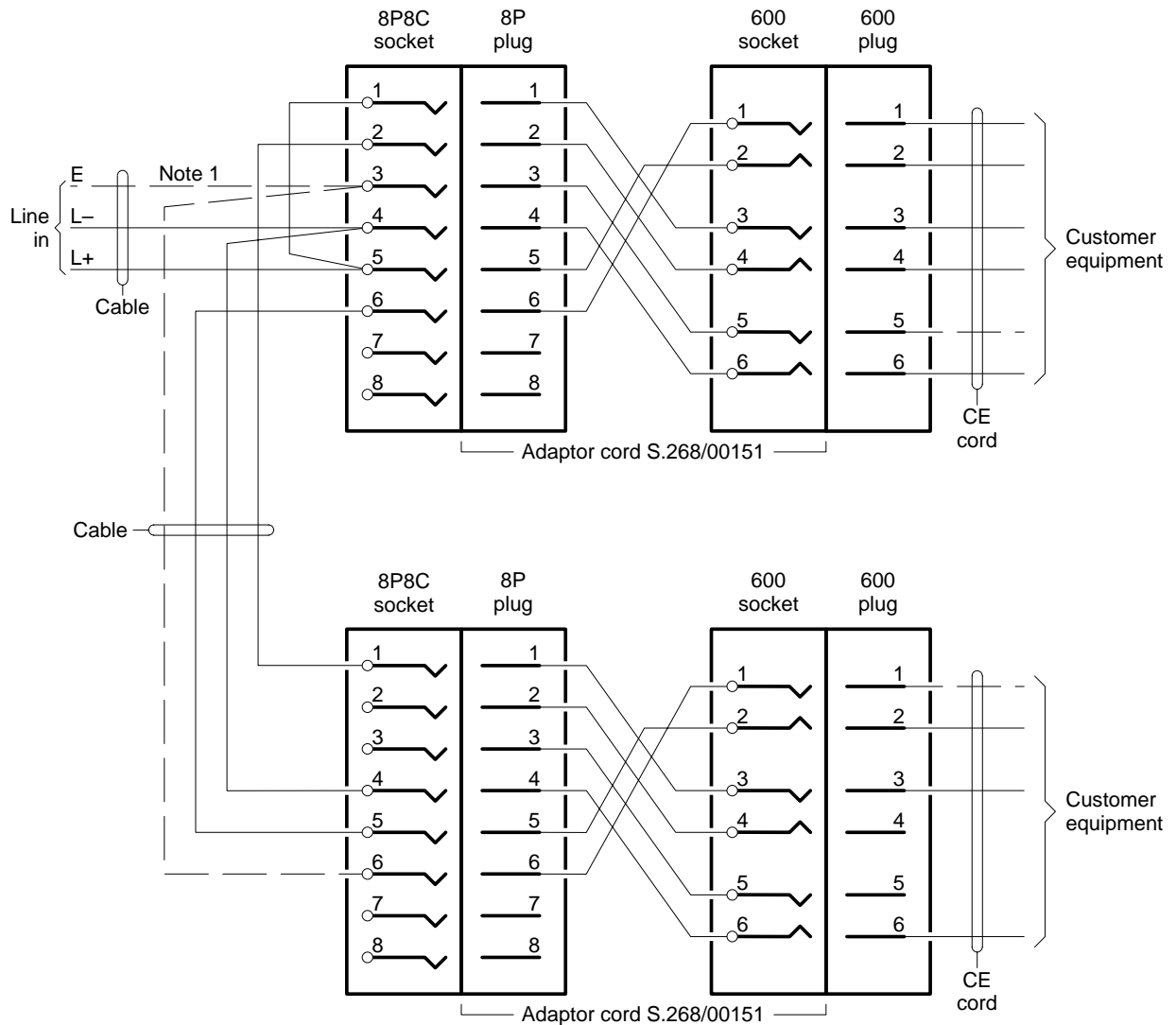

**Notes:**

1. If earth, TRC or CES connection is required, connect as shown thus - - - - -.
2. There is no equivalent standard connection mode per Attachment A01. Modern ring detect equipment is simply connected across the line (L+ & L-).

**Mode M 26 4-wire line with through connection or loopback facility between lines 1 and 2**

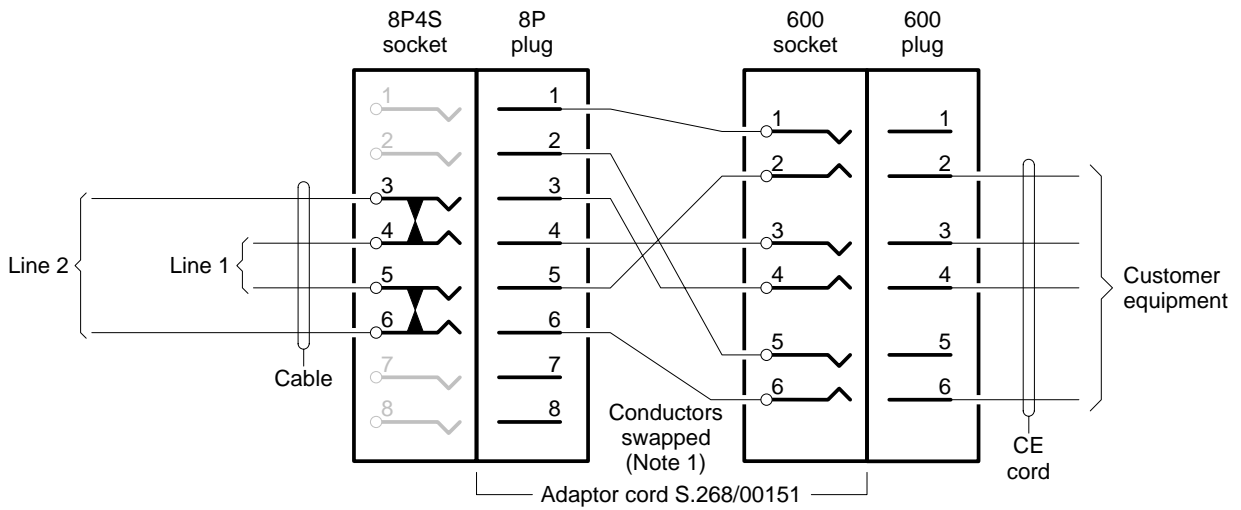

**Notes:**

1. In the 600 socket of the adaptor cord, alter the cord conductor connections as follows:
  - swap the conductors on 4 and 5;
  - remove the conductor on 6, lay it aside, and shift the conductor from 1 to 6;
  - shift the conductor from 3 to 1;
  - connect the conductor that was on 6 to 3.

Mark the rear of the socket, "NON-STANDARD — CORD TRANSPOSED".

2. The equivalent standard connection mode per Attachment A01 is mode 83E.

**Mode M 27 2-wire line with additional socket/s wired for 4-wire composite service**

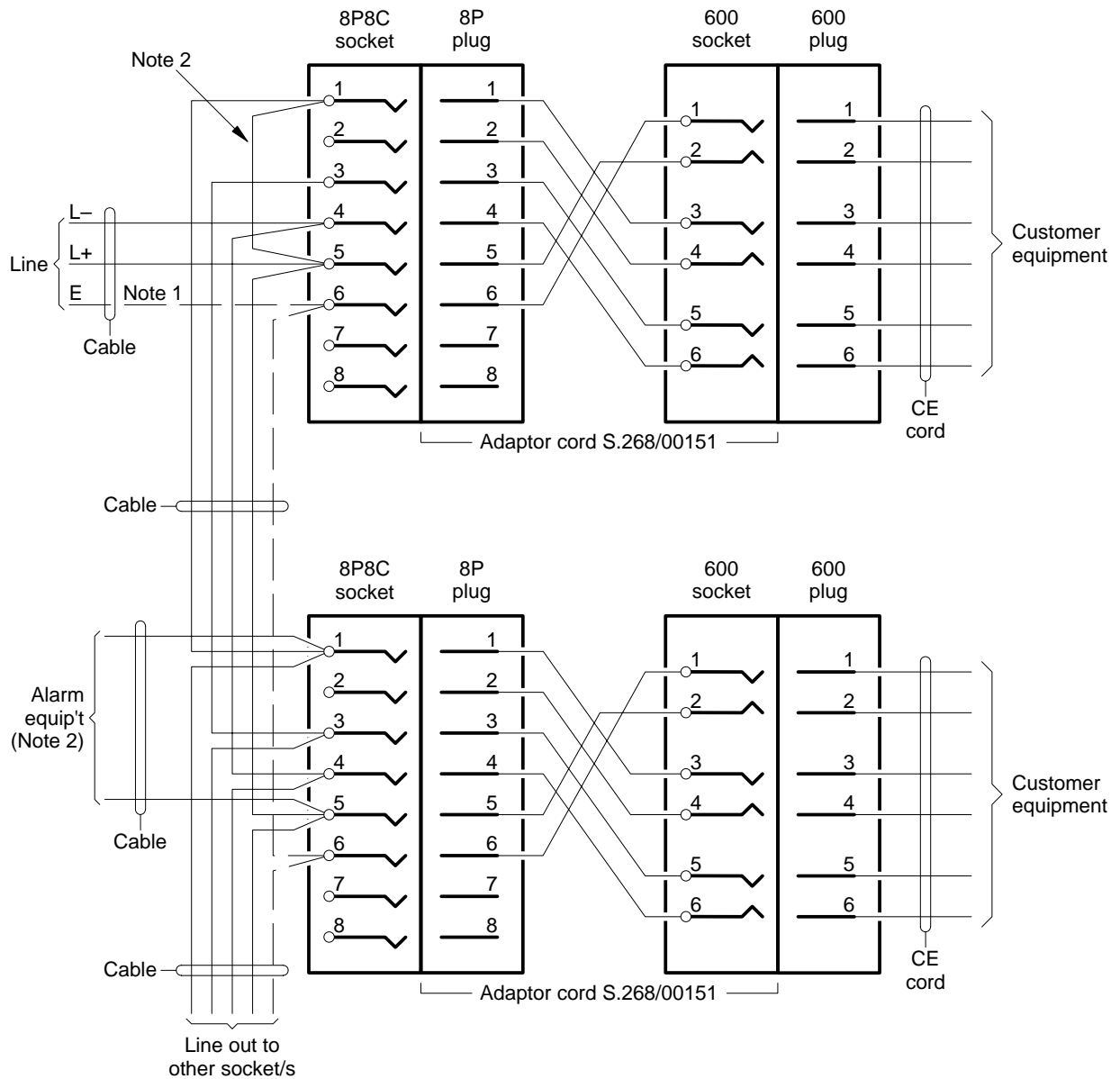

**Notes:**

1. If earth, TRC or CES connection is required, connect as shown thus - - - - -.
2. If alarm equipment is required, remove the link between terminals 1 & 5 in the first socket, and connect the alarm equipment between terminals 1 & 5 at any socket.
3. There is no equivalent standard connection mode per Attachment A01. With the original mode, an additional wire was required between sockets for commoning of telephone dial spark quench circuits to prevent tinkling of bells during decadic (pulse) dialling. This connection mode is not necessary with modern customer equipment which has tone dialling and/or anti-tinkle circuitry.

## Mode M 28 2-wire line with optional earth, manual switching of both legs via changeover (C/O) switch

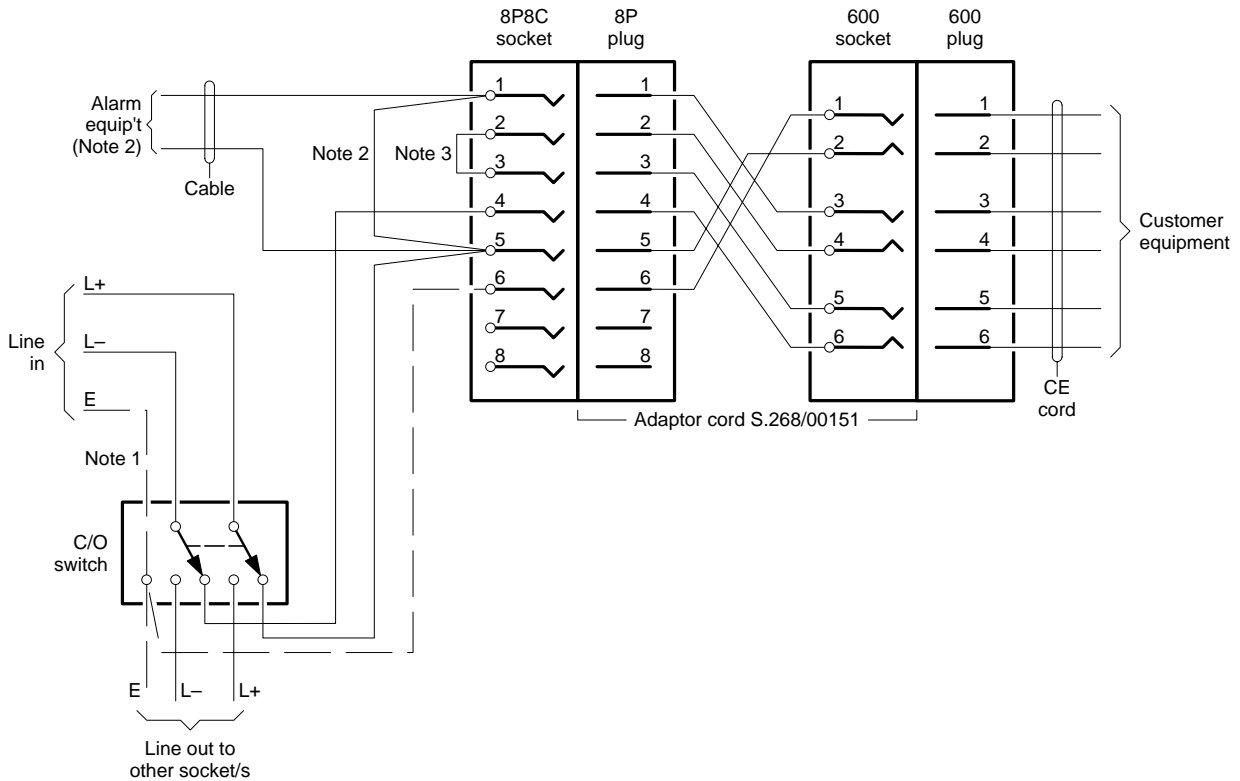

### Notes:

1. If earth, TRC or CES connection is required, connect as shown thus - - - - -.
2. If alarm equipment is required, remove the link between terminals 1 & 5 in the socket, and connect the alarm equipment between terminals 1 & 5.
3. Strap terminals 2 & 3 in the socket.
4. There is no equivalent standard connection mode per Attachment A01, but the closest equivalent is mode 88A. Modern alarm equipment is simply connected across the line (L+ & L-).

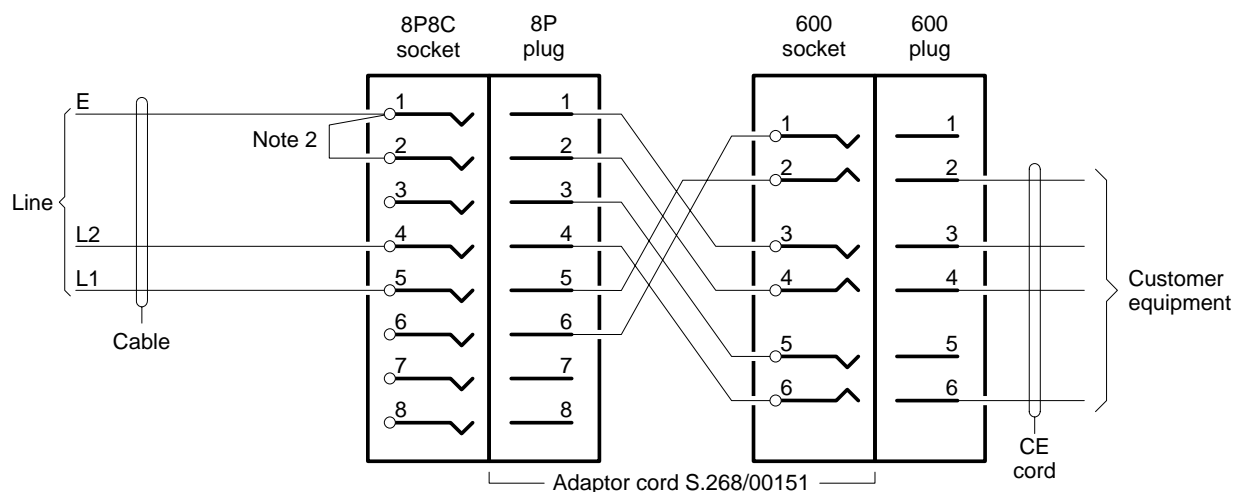
**Mode M 29    Use Mode M 9****Mode M 30    2-wire line with earth (telegraph type applications)****Notes:**

- For telegraph, data and similar applications where identification of line conductors is required, the terminations of the line will be as follows:
  - terminal 5 is the 'Receive' of the terminal equipment (L1);
  - terminal 4 is the 'Send' of the terminal equipment (L2).
- This mode may be specified without an earth connection, but in all cases terminals 1 & 2 will be strapped.
- The equivalent standard connection mode per Attachment A01 is mode 81A.

## Mode M 31 2-wire line with earth (telegraph type applications), diode test termination

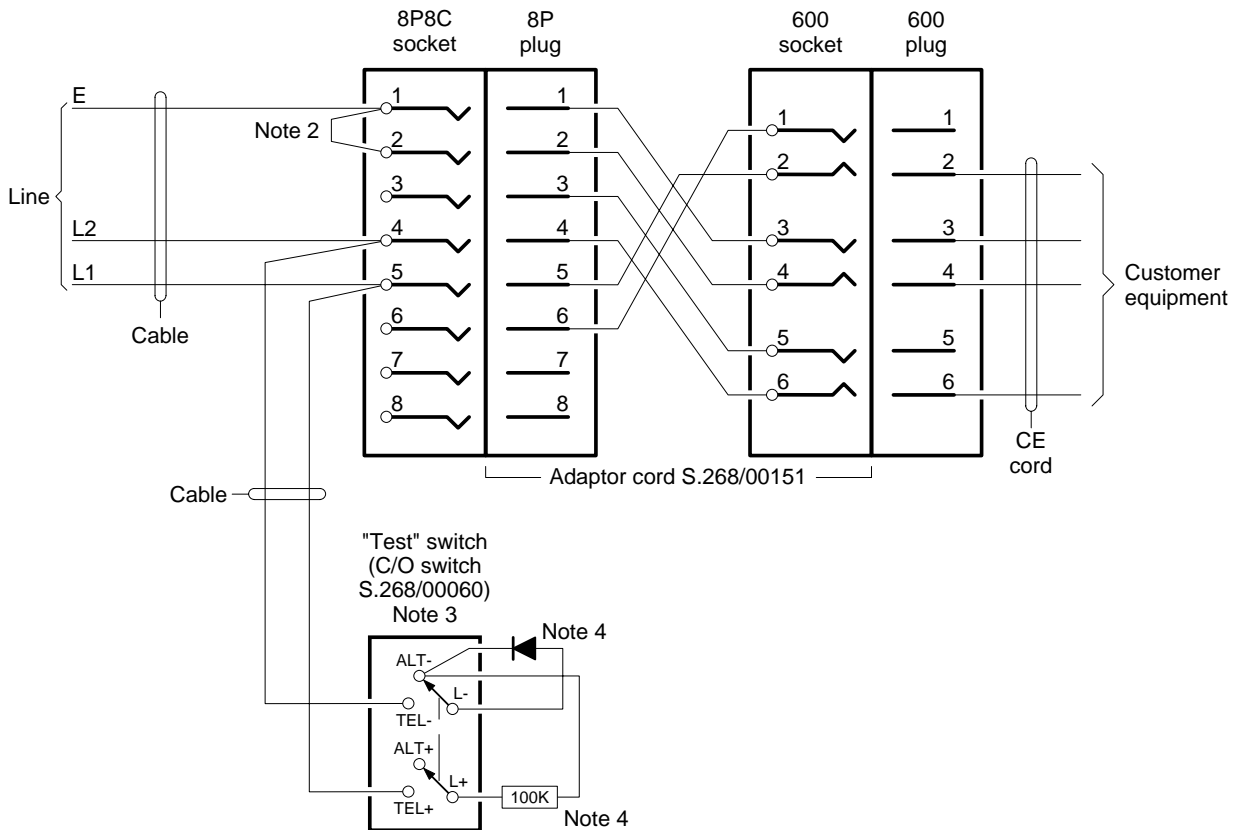

**Notes:**

1. For telegraph, data and similar applications where identification of line conductors is required, the terminations of the line will be as follows:
  - terminal 5 is the 'Receive' of the terminal equipment (L1);
  - terminal 4 is the 'Send' of the terminal equipment (L2).
2. This mode may be specified without an earth connection, but in all cases terminals 1 & 2 will be strapped.
3. With this wiring configuration, a test termination is achieved manually by operation of a C/O switch wired as shown. The switch should be suitably labelled (eg. "NORMAL" and "TEST"). Where the switch and diode circuit are not justified, use mode M 30.
4. Use diode general purpose type 1N4004 (400V/1A) or 1N4007 (1000V/1A) and 100k (¼W) resistor connected to the switch screw terminals as shown. A diode/resistor termination is used to avoid short-circuiting the line if the switch is accidentally operated during normal service.
5. The equivalent standard connection mode per Attachment A01 is:
  - mode 81B (using test plug); or
  - mode 86C (using switching socket); or
  - mode 87C (using switching socket); or
  - mode 88C (using manual test switch).

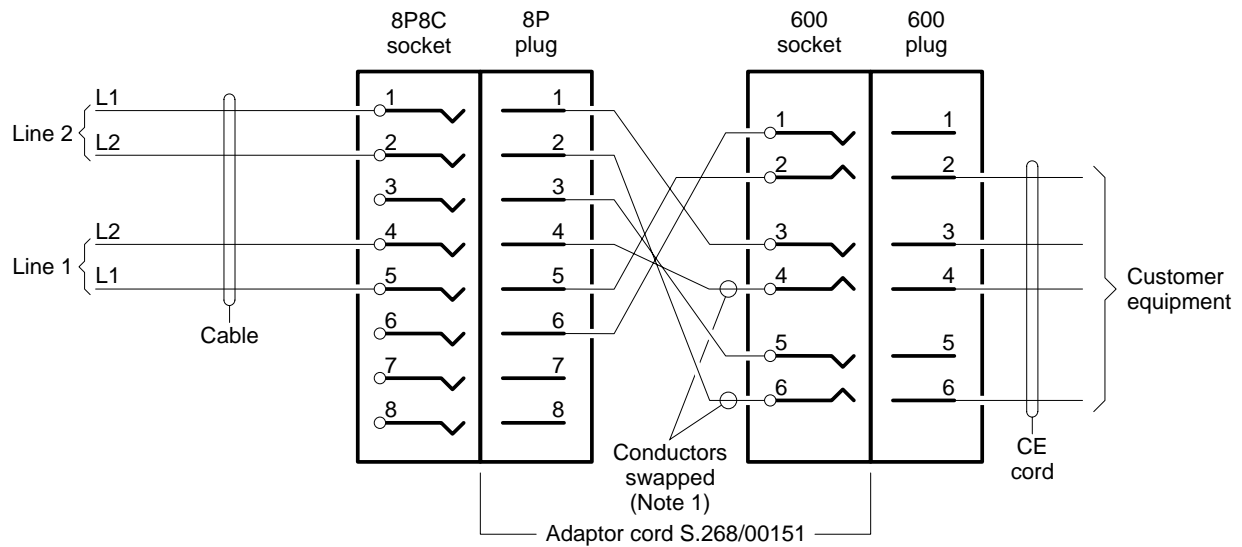
**Mode M 32 Two 2-wire lines or 4-wire line (telegraph type applications)****Notes:**

1. In the 600 socket of the adaptor cord, swap over the cord conductors on terminals 4 & 6. Mark the rear of the socket, "NON-STANDARD — CORD TRANSPOSED ON 4 & 6".
2. By changing the line 1/line 2 connection to balanced (rather than split) pairs and modifying the adaptor cord as shown, this ensures the equipment can be connected via integrated cabling to AS/NZS 3080 using the existing wiring and 8P8C socket.
3. Either Line 1 or Line 2, or both Line 1 and Line 2, may be connected.
4. For telegraph, data and similar applications where line identification is required, the terminations of the lines will be as follows:
  - terminals 5 & 2 are the 'Receive' of the terminal equipment (Line 1);
  - terminals 1 & 4 are the 'Send' of the terminal equipment (Line 2).
5. The equivalent standard connection mode per Attachment A01 is mode 84G.

## Mode M 33 Two 2-wire lines or 4-wire line (telegraph type applications), diode test termination

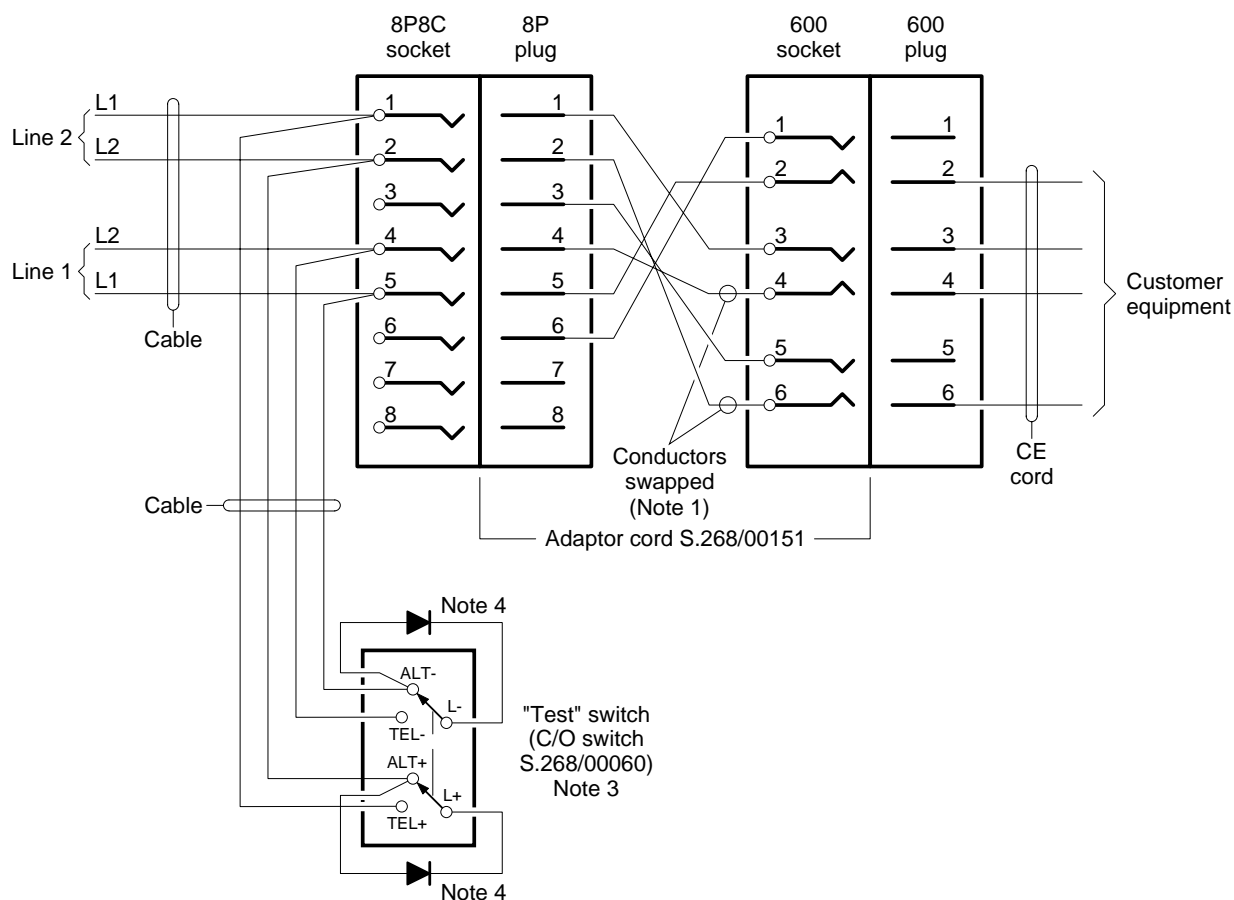

### Notes:

1. In the 600 socket of the adaptor cord, swap over the cord conductors on terminals 4 & 6. Mark the rear of the socket, "NON-STANDARD — CORD TRANSPOSED ON 4 & 6".
2. Where the equipment is to be connected via integrated cabling to AS/NZS 3080 using the existing wiring and 8P8C socket, the switch and diode termination must be foregone and the equipment connected as a mode M 32.
3. With this wiring configuration, a test termination is achieved manually by operation of a C/O switch wired as shown. The switch should be suitably labelled (eg. "NORMAL" and "TEST"). Where the switch and diodes are not justified, use mode M 32.
4. Use diode general purpose type 1N4004 (400V/1A) or 1N4007 (1000V/1A) connected to the switch screw terminals as shown.
5. Either Line 1 or Line 2, or both Line 1 and Line 2, may be connected.
6. For telegraph, data and similar applications where line identification is required, the terminations of the lines will be as follows:
  - terminals 5 & 2 are the 'Receive' of the terminal equipment (Line 1);
  - terminals 1 & 4 are the 'Send' of the terminal equipment (Line 2).
7. The equivalent standard connection mode per Attachment A01 is:
  - mode 84G (no test termination); or
  - mode 84N (no test termination); or
  - mode 82J (using test plug); or
  - mode 86H (using switching socket); or
  - mode 87H (using switching socket); or
  - mode 89F (using manual test switch).

**Mode M 34 2-wire line with optional earth, connection of equipment with series ring detect facility only**

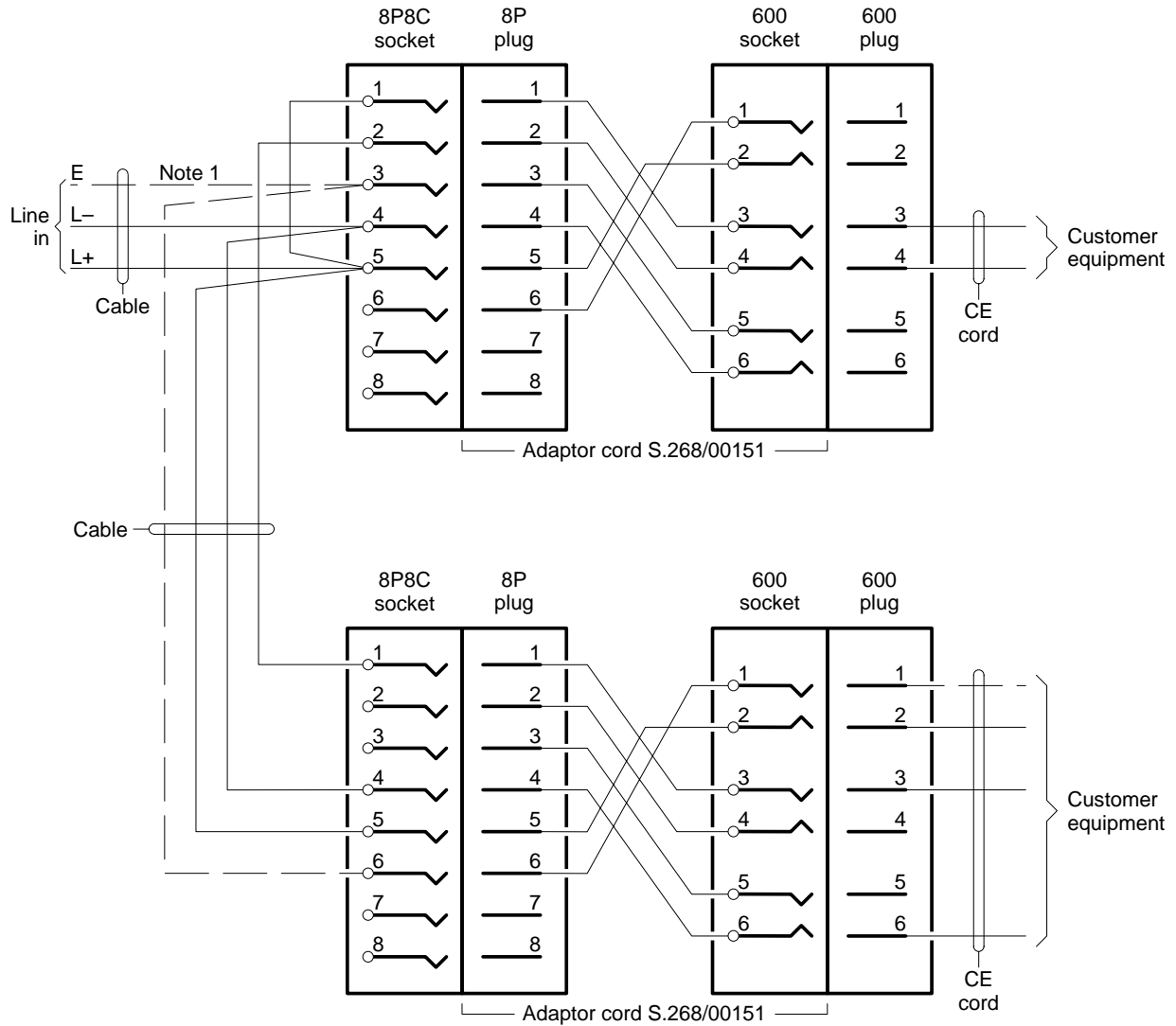

**Notes:**

1. If earth, TRC or CES connection is required, connect as shown thus - - - - -.
2. There is no equivalent standard connection mode per Attachment A01. Modern ring detect equipment is simply connected across the line (L+ & L-).

**Mode M 35 2-wire line with separate negative battery and earth feed**

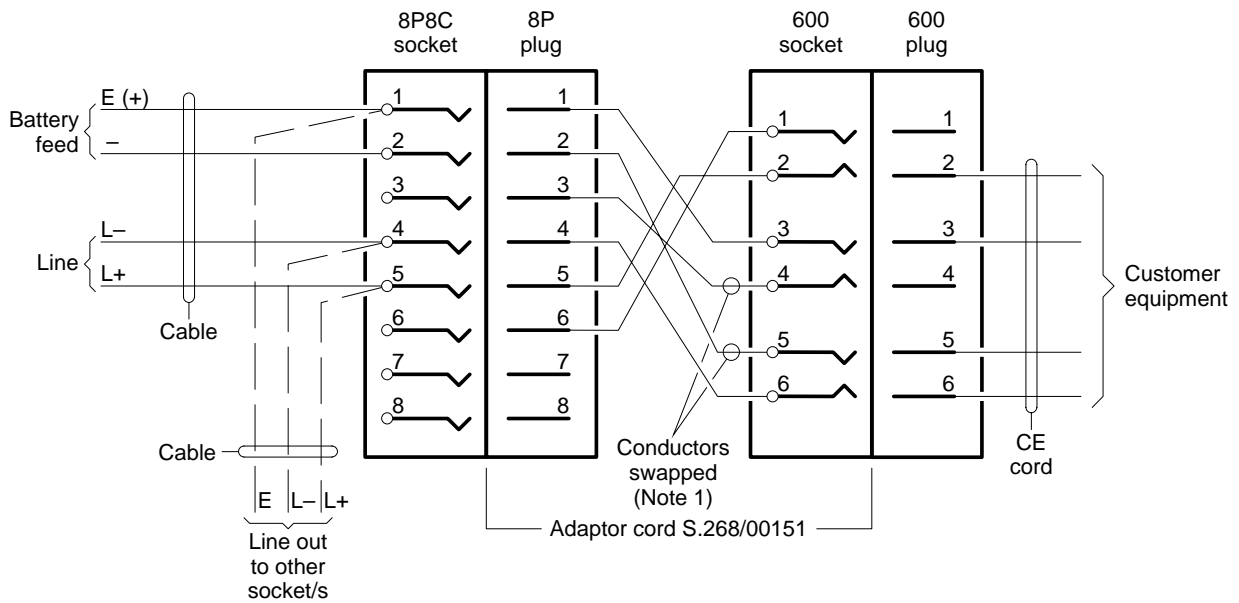

**Notes:**

1. In the 600 socket of the adaptor cord, swap over the cord conductors on terminals 4 & 5. Mark the rear of the socket, "NON-STANDARD — CORD TRANSPOSED ON 4 & 5".
2. By changing the line 1/line 2 connection to balanced (rather than split) pairs and modifying the adaptor cord as shown, this ensures the equipment can be connected via integrated cabling to AS/NZS 3080 using the existing wiring and 8P8C socket.
3. If connection to other sockets is required, connect as shown thus - - - - -.
4. The equivalent standard connection mode per Attachment A01 is mode 84J.

## Mode M 36 2-wire telex line or telegraph line with earth, customer equipment with standby or alternative teleprinter/s

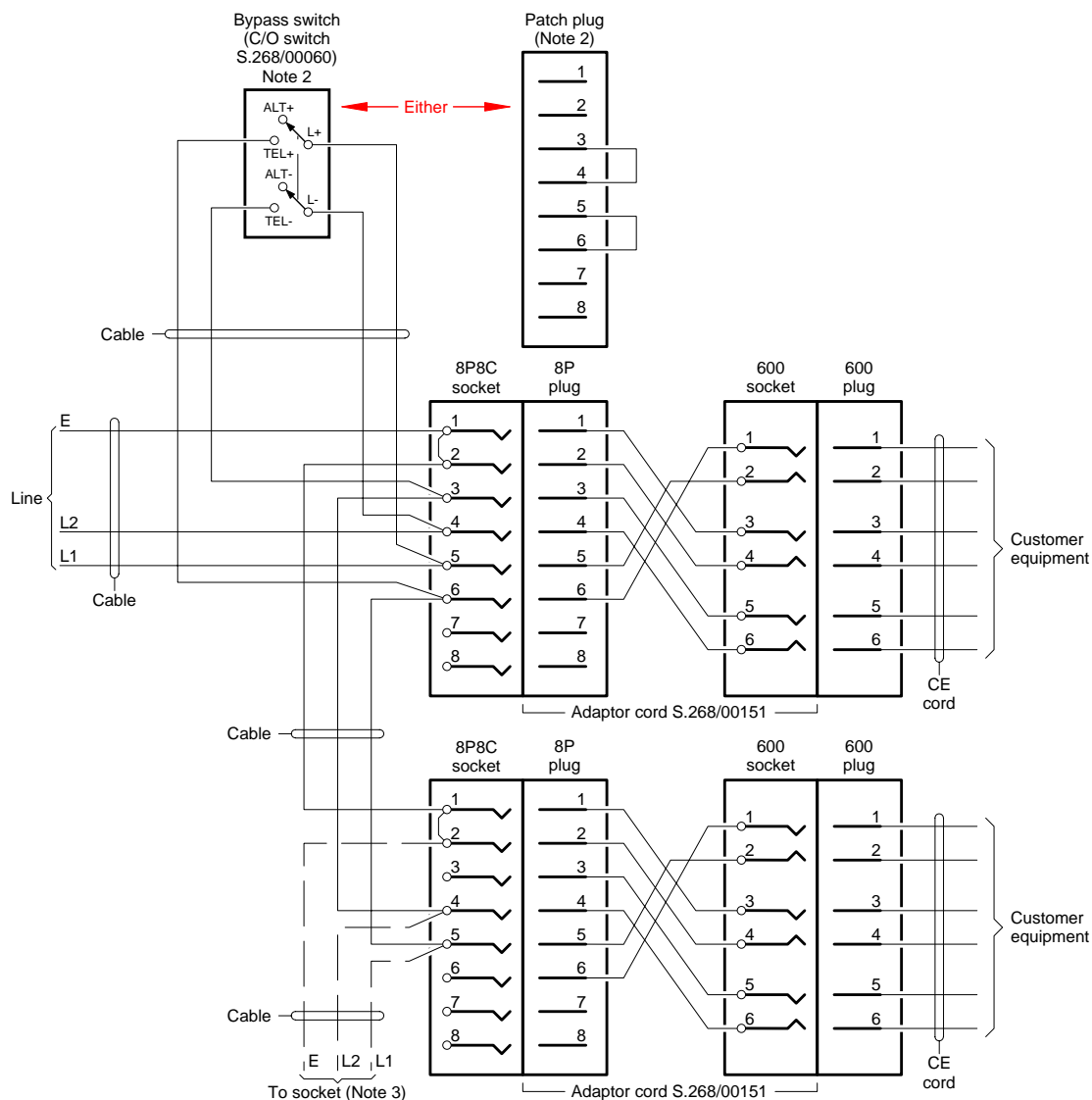

### Notes:

- For telegraph, data and similar applications where identification of line conductors is required, the terminations of the line will be as follows:
  - terminal 5 is the 'Receive' of the terminal equipment (L1);
  - terminal 4 is the 'Send' of the terminal equipment (L2).
- Legs L1 and L2 are connected through to other socket/s via circuitry in the customer equipment. If the line needs to be extended to other sockets when the customer equipment is unplugged, socket contacts 3 & 4 and 5 & 6 must be bridged by one of the following methods:
  - insertion of wire straps in the socket (must be done by a licensed cabler);
  - operation of a bypass switch wired as shown; or
  - insertion of a patch plug in place of the customer equipment plug.
 Where a patch plug is used, it can be "parked" in an adjacent, unterminated socket (ie. dual socket installation) with each socket suitably labelled (eg. "EQUIPMENT" and "PATCH PLUG").
- To socket for second teleprinter where two machines are required for duplex operation.
- The equivalent standard connection mode per Attachment A01 is:
  - mode 84B (no socket switching); or
  - mode 84K (using patch plug); or
  - mode 86A (using switching socket); or
  - mode 87A (using switching socket); or
  - mode 89E (using manual bypass switch).

### Mode M 37 2-wire line with optional earth, private radio service

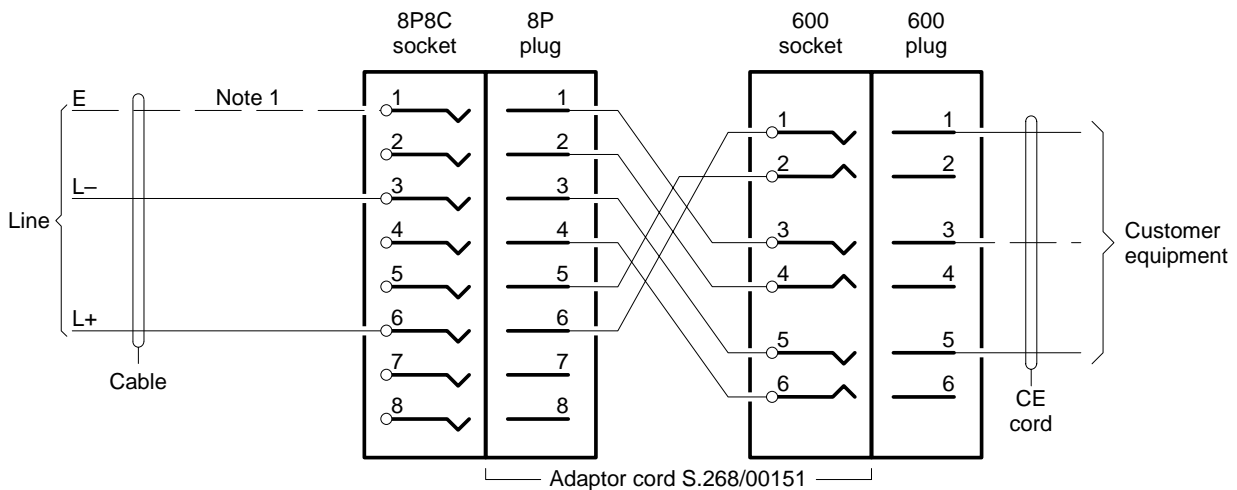

Notes:

1. If earth, TRC or CES connection is required, connect as shown thus - - - - -.
2. The equivalent standard connection mode per Attachment A01 is mode 81D.

### Mode M 38 2-wire line with optional earth, manual switching of both legs via changeover (C/O) switch, private radio service

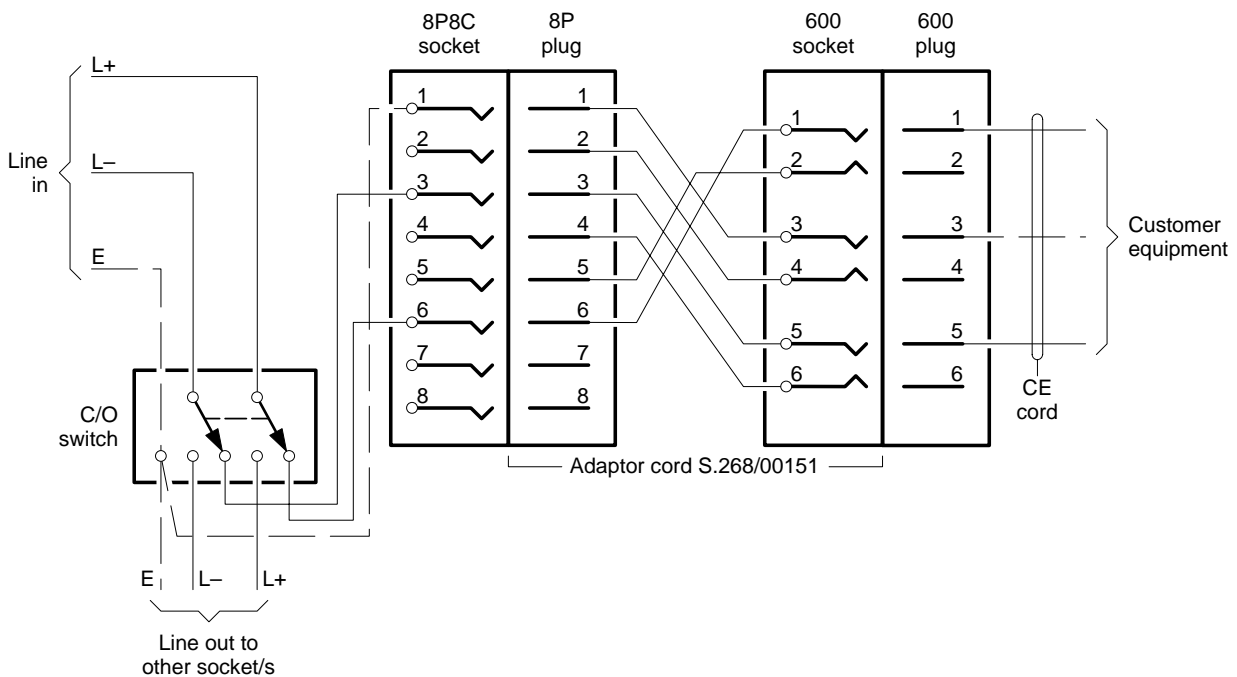

Notes:

1. If earth, TRC or CES connection is required, connect as shown thus - - - - -.
2. The closest equivalent standard connection mode per Attachment A01 is mode 88A. TOs (sockets) may be connected as mode 81D if required.

**Mode M 39 2-wire line, private radio service, customer equipment switching on both legs**

**(a) No earth**

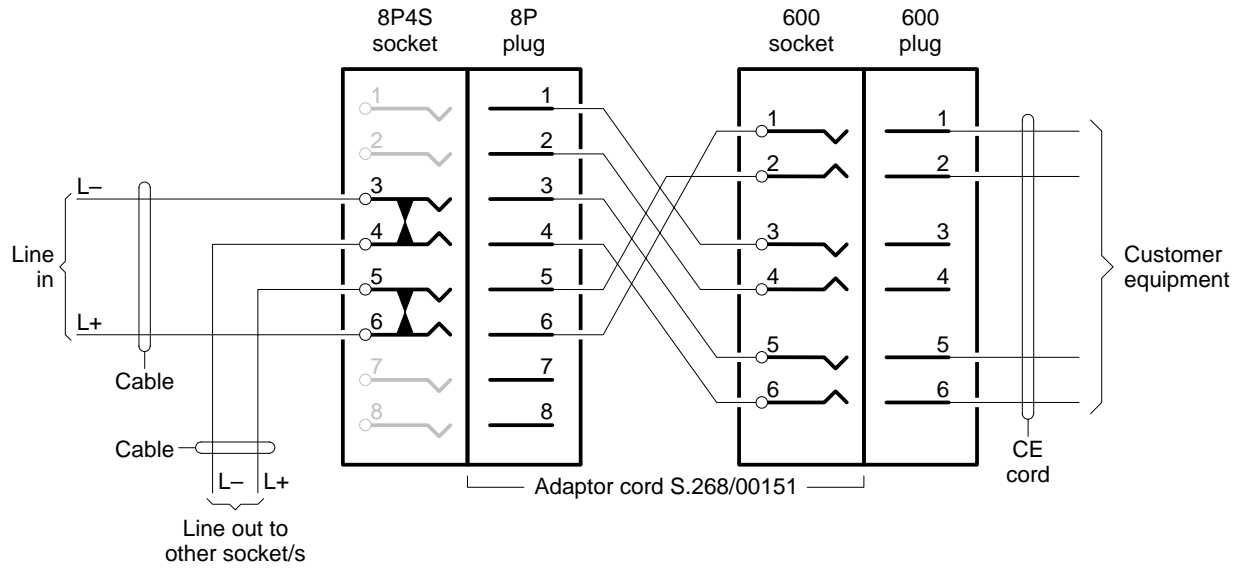

Note: The equivalent standard connection mode per Attachment A01 is mode 83A with the line in/out connections reversed.

## Mode M 39 (continued)

### (b) With earth

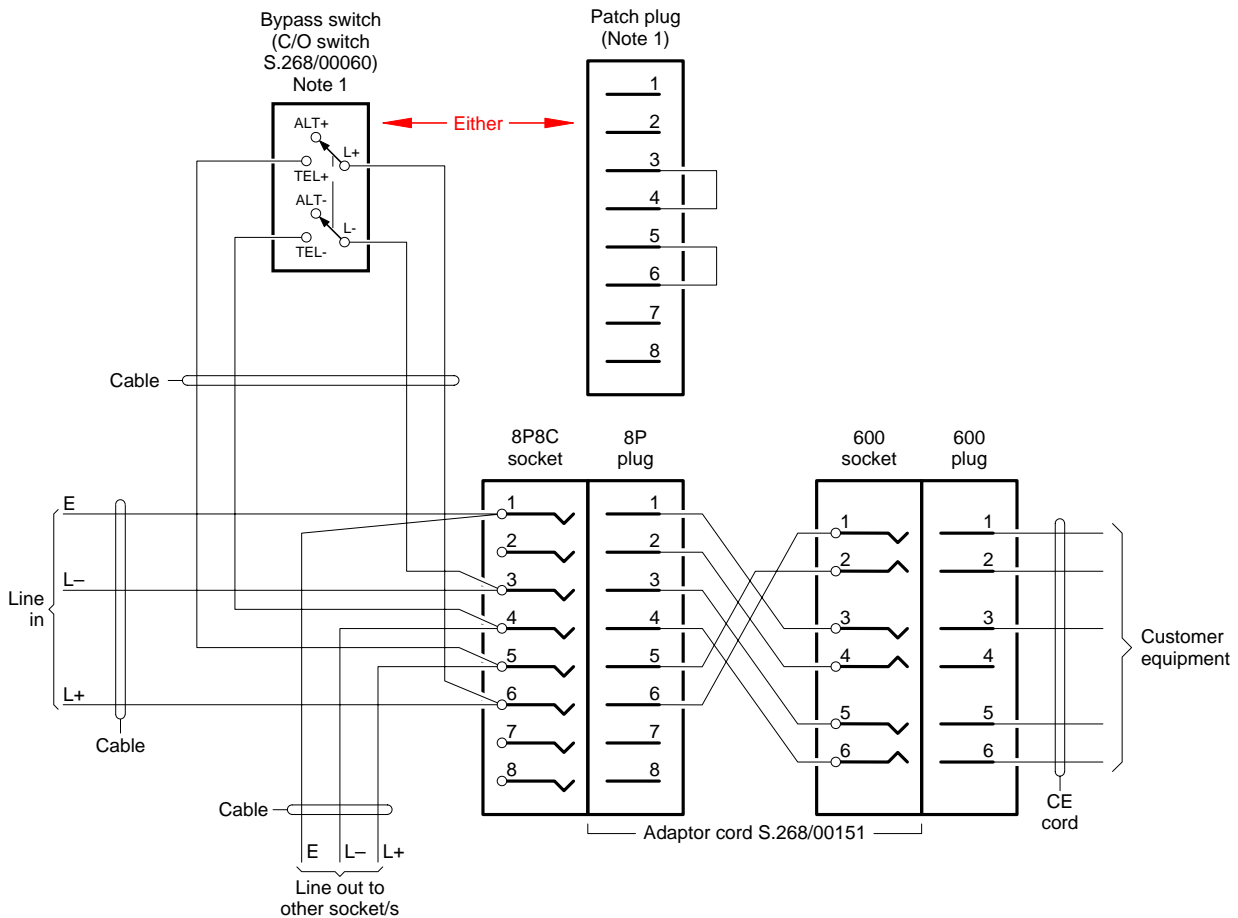

#### Notes:

- Legs L+ and L- are connected through to other socket/s via circuitry in the customer equipment. If the line needs to be extended to other sockets when the customer equipment is unplugged, socket contacts 3 & 4 and 5 & 6 must be bridged by one of the following methods:
  - insertion of wire straps in the socket (must be done by a licensed cabler);
  - operation of a bypass switch wired as shown; or
  - insertion of a patch plug in place of the customer equipment plug.
 Where a patch plug is used, it can be "parked" in an adjacent, unterminated socket (ie. dual socket installation) with each socket suitably labelled (eg. "EQUIPMENT" and "PATCH PLUG").
- The equivalent standard connection mode per Attachment A01 is:
  - mode 84B (no socket switching); or
  - mode 84K (using patch plug); or
  - mode 86A (using switching socket); or
  - mode 87A (using switching socket); or
  - mode 89E (using manual bypass switch).

**Mode M 40 2-wire line with optional earth**

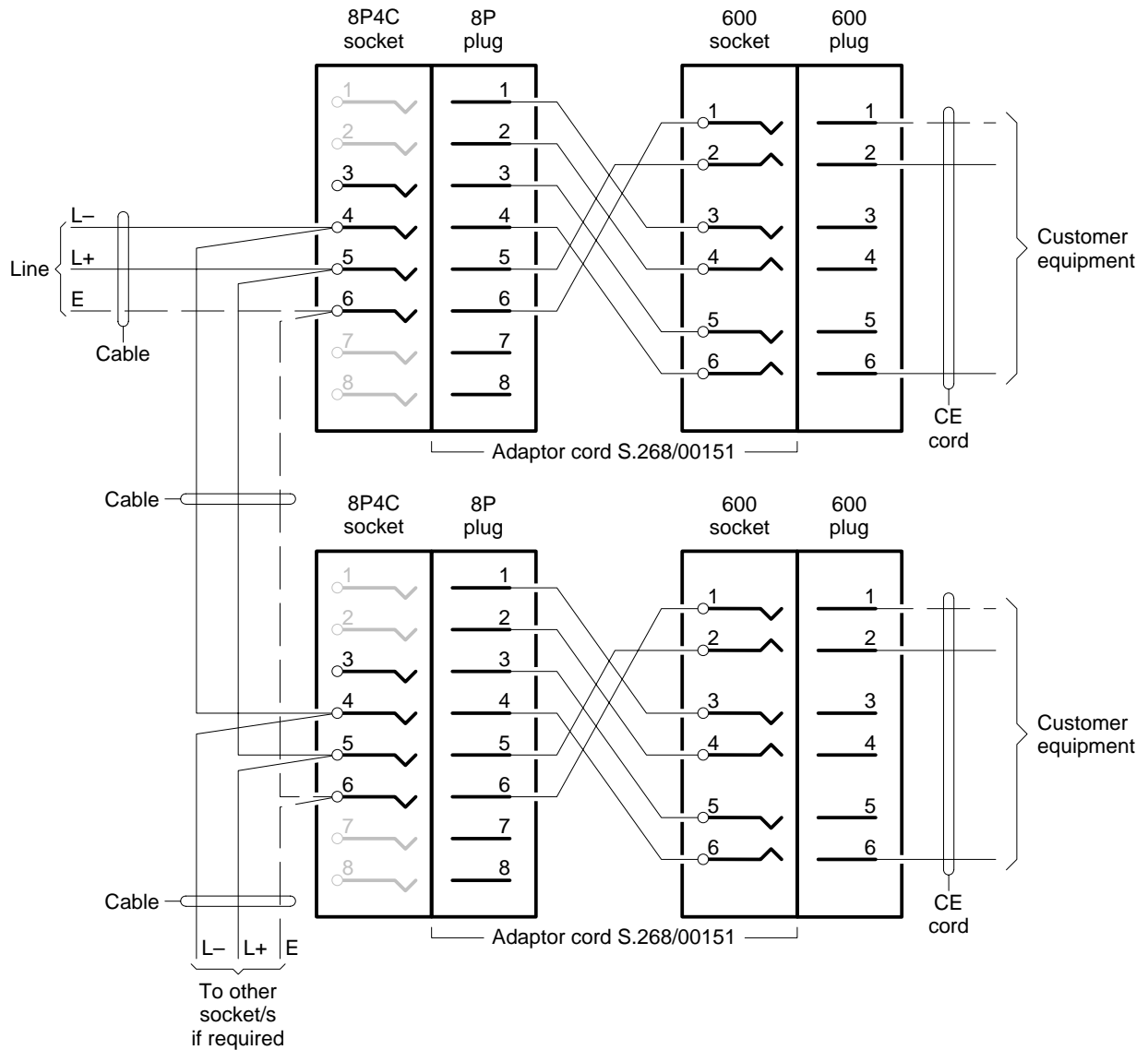

**Notes:**

1. If earth, TRC or CES connection is required, connect as shown thus - - - - -.
2. The equivalent standard connection mode per Attachment A01 is mode 81A.

**— END OF ATTACHMENT —**